

# PalmSens4™ iR Compensation Module

For using iR compensation with your PalmSens4



## Contents

Description.....	2
Positive Feedback .....	2
Software .....	2
Main Specifications .....	3

## Description

IR Compensation for PalmSens4 is available as an in-factory add-on module. The resistance between the reference electrode and the double layer of the specimen can cause a significant potential drop, decreasing the applied potential where it is required. The module provides positive feedback to compensate for the iR drop between the Reference electrode and the outside of the double layer of the electrochemical cell.

## Positive Feedback

The PalmSens4 iR Compensation module works by means of positive feedback. This is achieved through the use of a 16 bit MDAC in the module which scales the output of the current follower opamp to provide a positive feedback voltage which is proportional to the current through the cell. The compensation voltage is added into the summing point before the control amplifier and thus increases the applied potential to counteract the iR drop.

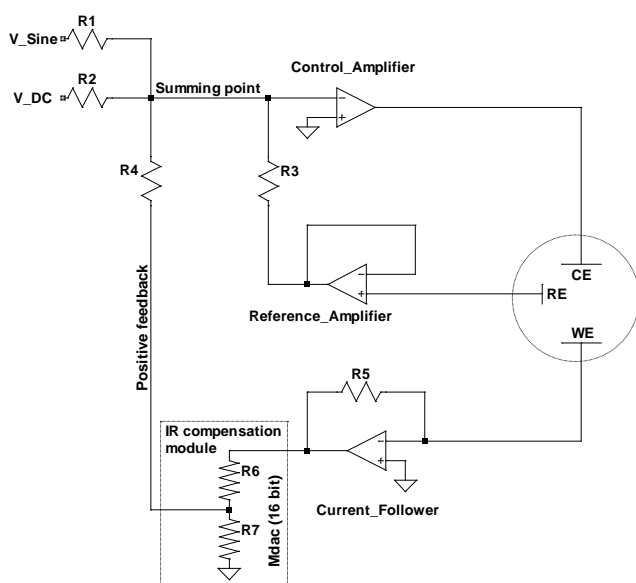

Positive feedback allows for fast scan rates up to 10 V/s, depending on the characteristics of the cell. If the potential error to compensate for becomes close to the value set for E applied, the system might become unstable. Using iR compensation limits the measurement bandwidth to 10 kHz.

## Software

The resistance to compensate for can be entered directly in the Method Editor in PSTrace:

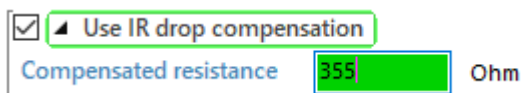

If auto ranging is not allowed for the compensation used in combination with the selected current ranges, this is shown in the Method Editor:

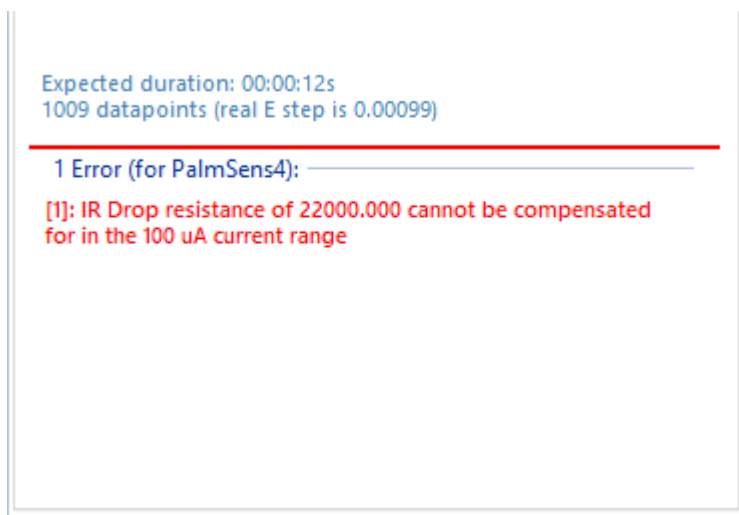

Make sure a single current range is selected in these circumstances.

## Main Specifications

<b>Resolution of MDAC used for correcting potential</b>	16 bit
<b>Max. compensated resistance</b>	1 MOhm
<b>Max. bandwidth with iR-drop compensation enabled</b>	10 kHz

## Supported Techniques

The following techniques are supported for use with iR compensation:

- Linear Sweep Voltammetry
- Cyclic Voltammetry
- Square Wave Voltammetry
- Differential Pulse Voltammetry
- Normal Pulse Voltammetry
- ChronoAmperometry
- Multistep Amperometry

Please don't hesitate to contact PalmSens for more details:  
[info@palsens.com](mailto:info@palsens.com)

**PalmSens BV**  
**The Netherlands**  
[www.palsens.com](http://www.palsens.com)

### DISCLAIMER

Changes in specifications and typing errors reserved.  
Every effort has been made to ensure the accuracy of this document. However, no rights can be claimed by the contents of this document.