

MUX8-R2™

MULTIPLEXER



Compatible with
PalmSens3, (Multi)PalmSens4, EmStat3 Blue and
EmStat4X LR and HR

Contents

Description.....	3
Stacking up to 128 channels	3
Configurations.....	4
Connectors	4
Cell Connection Options	5
Supported Switching Modes	6
Specifications.....	7
Functional Diagram	7
Dimensions	8
Software Support	8
MUX8-R2 with Integrated Potentiostat	9

➤ See for more information:
www.palmsens.com/mux8-r2

Description

The MUX8-R2 multiplexer extends a PalmSens3, PalmSens4, EmStat3 Blue, EmStat4X or a channel of a MultiPalmSens4 potentiostat. The multiplexer allows to increase productivity by automatically switching between up to 8 electrochemical cells. Each cell having their own WE, Sense or WE2, RE



Stacking up to 128 channels

Each multiplexer has a Link connector which can be used to daisy chain to another MUX8-R2 multiplexer, expanding the number of channels. A maximum of 16 multiplexers can be connected in a daisy chain, giving a maximum of 128 channels. Our PSTrace software detects automatically how many multiplexers are daisy chained and shows the available number of channels in the user interface.



Magnetic feet for easy stacking.

Configurations

The MUX8-R2 multiplexer is designed for use up to 128 channels with 2- or 3- electrode sensors or cells.

The multiplexer can be used with different electrode or sensor configurations:

1. Eight separate cells or sensors each with a working/sense, reference and counter electrode.
2. Eight separate cells or sensors each with a working/sense and combined reference and counter electrode.
3. Cell or sensor array with eight working/sense electrodes sharing one reference and one counter electrode.
4. Cell or sensor array with eight working/sense electrodes sharing one combined reference/counter electrode.

In all configurations the cells can be multiplexed, leaving the non-selected working electrodes either at open circuit (individually floating) or at Ground potential. When in configurations 3 and 4, the unselected channels are switched to Ground, they will have the working electrode's potential. This is due to the fact that the active WE is always at Ground potential.

You can easily change the hardware configuration of the MUX8-R2 as part of the measurement settings in our PStouch software or the PStouch app for Android.

MUX8-R2 Settings

- Connect Sense to WE
- Combine RE and CE
- Use Common RE and CE on Channel 1
- Unselected WE
 - Disconnect WE (floating)
 - Switch WE to GND

The hardware configuration can be set in our software.

Connectors

The MUX8-R2 has the following connectors:

Connector	Function
Input	Y-cable connects to both potentiostat sensor connector and (digital) AUX.
AUX	Can be used to measure auxiliary input like temperature or pH, and to switch external hardware using two digital control lines that can be set in our software.
Link	Connects to Input of next multiplexer, for daisy-chaining multiple multiplexers.
USB-C	For providing extra power in case more than two multiplexers are connected to a single instrument.
Channel 1-4	Connects to WE, Sense, WE2, RE and CE of channels 1-4.
Channel 5-8	Connects to WE, Sense, WE2, RE and CE of channels 5-8.

Cell Connection Options

Option A (default):

The channels are divided in two sets of four sensor cables joined with a D-Sub connector.

Order code: [CBL-MUX08R2-SNS-5S]

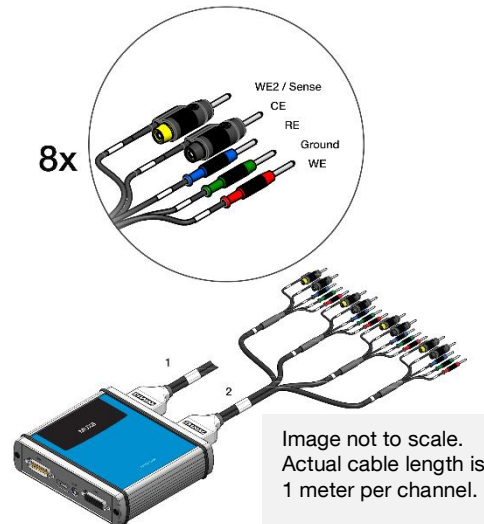

Option B:

The cable here shown at the right can be used in case the multiplexer needs to be connected to a fixed setup by means of soldering or screw-terminals.

Order code: [CBL-MUX08R2-HD]



Option C:

You can also connect one or two screw-terminals directly in the multiplexer.

Order code: [MUX08R2-ST]



Option D:

The SPE adapter for our MUX8-R2 multiplexer allows you to connect 8x Screen Printed Electrodes (SPE's). The pitch of the SPE connector is 2.54 mm and compatible with the most popular brands of SPE's.

Order code: [MUX08R2-SPE]

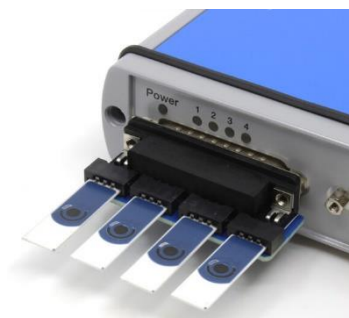

Supported Switching Modes

In *sequential* mode each channel is set before the next measurement starts. In *alternating* mode, the channels are quickly scanned during each interval time giving a virtual-simultaneous measurement across the selected channels.

Voltammetric techniques	Sequential	Alternating
▪ Linear Sweep Voltammetry	✓	-
▪ Cyclic Voltammetry	✓	-
▪ Fast Cyclic Voltammetry	✓	-
▪ AC Voltammetry	✓	-
▪ Differential Pulse Voltammetry	✓	-
Pulsed techniques:		
▪ Square Wave Voltammetry	✓	-
▪ Normal Pulse Voltammetry	✓	-
▪ Stripping Chronopotentiometry	✓	-
Amperometric techniques		
▪ Chronoamperometry	✓	✓
▪ Zero Resistance Amperometry	✓	✓
▪ Multistep Amperometry	✓	-
▪ Fast Amperometry	✓	-
▪ Pulsed Amperometric Detection	✓	-
▪ Multiple-Pulse Amperometric Detection	✓	-
Galvanostatic techniques		
▪ Linear Sweep Potentiometry	✓	-
▪ Chronopotentiometry	✓	✓
▪ Multistep Potentiometry	✓	-
▪ Open Circuit Potentiometry	✓	✓
▪ Stripping Chronopotentiometry	✓	-
Other		
▪ Mixed Mode	✓	-
▪ Impedance Spectroscopy (EIS/GEIS)	✓	-

Specifications

System specifications

▪ number of channels	8 (up to 128 channels when daisy chained)
▪ multiplexer	switches 8 x [WE, WE2 or Sense, RE, CE]
▪ on resistance for WE	1.5 ohm typical
▪ charge injection for WE	20 pC typical
▪ leakage current	< 55 pA (20 pA typical) at 25 °C
▪ switching time	2 ms
▪ compliance voltage	±10 V
▪ maximum current	70 mA (when used with EmStat3+ Blue or EmStat4X HR)

Limitations for Electrochemical Impedance Spectroscopy (EIS)

▪ max. frequency for EIS	100 kHz when switching WE/S, RE and CE 1 MHz when switching WE/S and RE+CE combined (2 electrodes configuration)
--------------------------	--

Functional Diagram

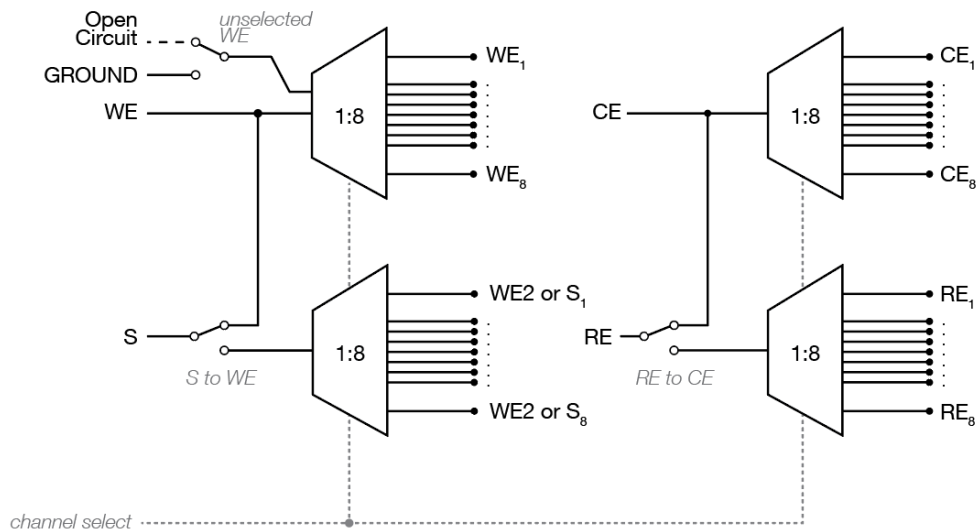

Dimensions

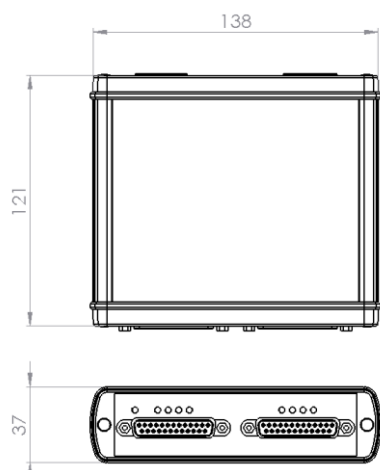

Dimensions in mm

Software Support



The MUX8-R2 is supported by PStouch and MultiTrace for Windows and the PStouch app for Android.



MUX8-R2 with Integrated Potentiostat

EmStat MUX8-R2™

The MUX8-R2 multiplexer is also available with integrated EmStat3 or EmStat4 potentiostat. This very compact combination allows for a high productivity with a small footprint.



➤ See for more information:
www.palmsens.com/emstatmux

Please don't hesitate to contact PalmSens for more details:
info@palsens.com

PalmSens BV
The Netherlands
www.palsens.com

DISCLAIMER

Changes in specifications and typing errors reserved.
Every effort has been made to ensure the accuracy of this document. However, no rights can be claimed by the contents of this document.