

sensit[™] / *WEARABLE*
Development Kit

User Manual

Version 07-2024-001



WARNING

DO NOT CONNECT THE SENSIT WEARABLE TO A PC OR CHARGER VIA ITS USB-C PORT WHILE A PHYSICAL CONNECTION OF ITS POGO PINS AND A HUMAN BODY IS PRESENT.

A COMBINED MALFUNCTION OF THE PC OR CHARGER AND THE SENSIT WEARABLE MAY RESULT IN SERIOUS INJURY OR DEATH DUE TO ELECTROCUTION.

In case of problems

First make sure to check the “Troubleshooting” section in this document and the Knowledge Base on our website:

www.palmsens.com/knowledgebase/

This page contains support information on installation, software updates, and training.

Please make sure your software and firmware are up-to-date.

In case of persistent problems, use the contact form:

www.palmsens.com/contact/

give us a call: +31 30 2459211
or send an email: info@palmsens.com

Limited Warranty

Except as otherwise provided herein, PalmSens BV warrants to buyer three years from the date title to the product passes (transfer date of goods from seller to buyer), each product sold hereunder will be free of defects in materials or workmanship and will conform to specifications set forth in PalmSens BV' published data sheets or, where applicable, user manuals for PalmSens BV' system products in effect at the time title passes.

PalmSens BV's sole liability and responsibility for products under this warranty is for PalmSens BV to repair or replace any product that is returned to it by buyer or credit buyer's account for such returned product, provided that PalmSens BV shall have the right to reject any such remedy where PalmSens BV determines that the warranty does not apply product returned to PalmSens BV for warranty service will be shipped to PalmSens BV at buyer's expense and will be returned to buyer at PalmSens BV' expense. PalmSens BV' obligation to honor its warranty for a product is contingent upon receipt of payment in full for such product.

Items that are subject to wear and tear such as cell and connection cables, electrode connectors, crocodile clips, batteries, etc., are excluded from the warranty.

See our website for more detailed information:

www.palmsens.com/terms-and-conditions/

Disclaimers

PalmSens BV cannot guarantee that its instruments will work with all computer systems, operating systems, and third-party software applications hardware/software. The information in this manual has been carefully checked and is believed to be accurate as of the time of compiling. However, PalmSens BV assumes no responsibility for errors that might appear. See Appendix A for CE declaration of conformity.

Copyrights

Sensit Wearable Manual.

Copyright © 2024, PalmSens BV, all rights reserved.

PSTrace, MultiTrace, PalmSens, EmStat, MultiEmStat and Sensit are trademarks of PalmSens BV.

No part of this document may be copied or reproduced in any form without the prior written consent of PalmSens BV.



1 Contents

1 About the Sensit Wearable	1
2 Operating the Sensit Wearable	2
2.1 Features	2
2.2 Switching on and off	2
2.3 Mounting and dismounting	3
2.4 USB and charging	3
2.5 Connecting	4
2.6 Indicators	7
3 Development Kit.....	8
3.1 Development Board	8
3.2 Universal adapter with velcro strap	9
4 Pin-out	10
4.1 Auxiliary (AUX) pin	11
5 Technical specifications	12
5.1 EIS accuracy contour plot	13
6 First Measurement.....	14
7 Troubleshooting	17
8 Maintenance and compliance	18
8.1 Battery	18
8.2 Temperature compliance.....	18
8.3 Humidity compliance	19
8.4 Temperature drift	19
8.5 Atmospheric pressure.....	19
8.6 Cleaning.....	19
8.7 Periodic calibration and preventive maintenance	20
8.8 Service and repair	20
8.9 RoHS Compliance	20
9 Links and tips.....	21
Appendix A - EU Declaration of conformity	22
Appendix B - EU Waste Electrical and Electronic Equipment (WEEE) directive.....	23
Appendix C - Sensit Wearable for OEM.....	24
Appendix D - Mounting bracket technical drawings	25

SEE FOR LATEST DOWNLOADS, APPLICATION NOTES,
AND MORE INFORMATION:

WWW.PALMSENS.COM/SENWB

2 About the Sensit Wearable

The Sensit Wearable is a wearable, lightweight, battery powered instrument for use with electrochemical (bio)sensors or electrochemical cells that are attached to the human body. The instrument is a low noise and low-current potentiostat and impedance analyzer which controls the potential applied to the sensor and measures the current response.

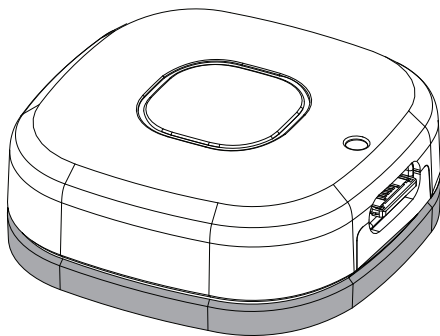

The Sensit Wearable mounted on mounting bracket.

3 Operating the Sensit Wearable

3.1 Features

The Sensit Wearable has a single button and two LED indicators. The following image shows an overview.

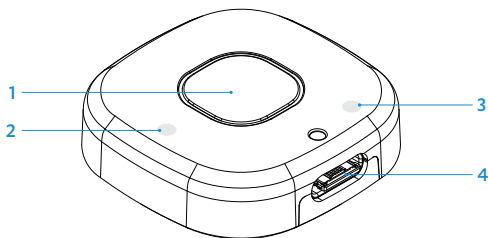

1. Button for powering on and off, or for triggering.
2. Blue status indicator
3. Orange charge indicator
4. USB-C port

3.2 Switching on and off

A single push on the button switches the device on. Push and hold the button for three seconds to switch it off again.

When the device is switched on and no script is running, the blue status LED will blink, indicating the device is idle.

3.3 Mounting and dismounting

The Sensit Wearable requires to be mounted on its mounting bracket before use. Make sure to align the two round markers on both the device and bracket before placing it on the bracket and twisting it 45 degrees clock-wise.

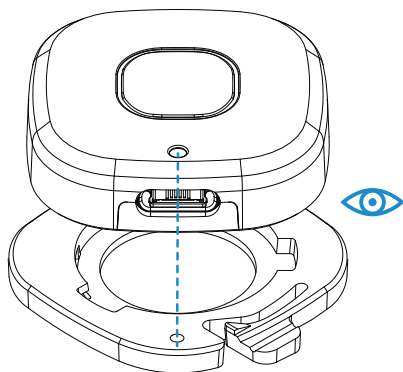

Dismounting the Sensit Wearable requires a combination of pushing down the small lever on the mounting bracket and rotating it back 45 degrees counter clock-wise while gently pulling.

3.4 USB and charging

The Sensit Wearable has a USB Type-C (USB-C) port and uses the High-Speed USB 2.0 specification. Charging of the Sensit Wearable can be done using the same USB-C port.

Any USB power source can be used for charging.

During charging the orange LED next to the USB-C port will be flashing with intervals of around 1 s. The following table shows the charge times.

Charge capacity	Charge time
25%	35 min
50%	65 min
75%	95 min
100%	165 min

[See section 6 for more information regarding battery life and power consumption.](#)

3.5 Connecting

For establishing a connection between a PC and the Sensit Wearable either the USB-C cable can be used or a Bluetooth 5.0 connection can be established.

3.5.1 Connecting via USB-C

Make sure the Sensit Wearable is switched on. If the appropriate drivers are installed, the PC will recognize the Sensit Wearable automatically when connecting via its USB-C port. The Sensit Wearable will appear in PStTrace as “Sensit Wearable”. Windows will also automatically assign a COM port which can be used in 3rd party applications like Tera Term for direct communication.

Settings for making a connection via the serial COM port are:

Speed: 230400 baud
Data: 8 bit
Parity: none
Stop bits: 1 bit
Flow control: none
Use LineFeed (LF) for new lines.

3.5.2 Connecting via Bluetooth

Every Sensit Wearable has a unique Bluetooth identifier. When the Sensit Wearable is powered on, it will advertise itself as PS-#### where the last four characters correspond to its Bluetooth MAC address.

The Sensit Wearable can be added as a new Bluetooth Device in Windows in “Settings > Bluetooth & devices > Devices”.

Before adding the Sensit Wearable as a Bluetooth Device in Windows, make sure to set “Bluetooth devices discovery” to “Advanced”.



PSTrace detects the Sensit Wearable without changing the “Bluetooth devices discovery” setting.

A pin code is required when connecting. This code can be found on the inside of the lid of the Development Kit box. It can also be deduced from the serial number of the Sensit Wearable:

THE BLUETOOTH PIN CODE CONSISTS OF THE LAST 6 DIGITS OF THE SERIAL NUMBER OF THE SENSIT WEARABLE. THE SERIAL NUMBER IS PRESENT AS QR CODE ON THE SENSIT WEARABLE.

FOR EXAMPLE:

SENSIT SERIAL NUMBER=4422407000502

PIN CODE=000502

Bluetooth connections can be maintained during hibernation without significant impact on power consumption. This enables very low power (long iteration time) measurements, while still providing live data to be received.

A Bluetooth connection is always leading, so if a Bluetooth connection is present it will not be possible to connect via its USB-C port. Secondly a USB connection will be severed if a Bluetooth connection is made to the Sensit Wearable.

3.6 Indicators

Blue LED default states are:

- Warning: blink 4 Hz
- Idle: blink 1 Hz
- Script running: solid on
- Off or hibernating: solid off
- In bootloader: blink 2 Hz

Orange LED default states are:

When the device is powered on and charging:

- Charging: blink slow (0.8 Hz)
- Charging issue: blink fast (6 Hz)
- >90 % charged: solid on

When the device is not charging:

- Battery charge OK: solid off
- Battery low: short pulse every 4 s

3.6.1 Custom LED behavior in MethodSCRIPT

In MethodSCRIPT the behavior of the blue LED can be changed with the “notify_led” command:

NM_IDLE:	blink 1 Hz
NM_PASS,	pulse 900 ms on 100 ms off
NM_BUSY:	solid on
NM_NOTICE:	pulse 100 ms on, 400 ms off
NM_FAIL:	blink 4 Hz
NM_WARN:	blink 4 Hz
NM_ERROR:	blink 4 Hz

4 Development Kit

This section explains how to use the accessories found in the Sensit Wearable Development Kit.

4.1 Development Board

The Sensit Wearable Development Board allows for breaking out the pogo pins of the Sensit Wearable to a screw connector and Lemo connector. The Lemo connector is compatible with the cell cable supplied with the Development Kit. In combination with the crocodile clips, it allows for connecting to electrochemical sensors or cells in any form factor. Also it allows for connecting to the supplied Dummy Cell.

See also section 7 “First Measurement.

4.1.1 Screen-Printed Electrode connector

The small SPE connector, also supplied with the Kit, can be screwed in the screw terminal of the Development Board, allowing for connecting Screen-Printed Electrodes with the standard pitch of 2.54 mm and a maximum width of 10 mm and a maximum thickness of 0.8 mm.

See next page for an illustration of the SPE connector mounted to the screw terminal of the Development Board.

PLEASE BE AWARE THAT USING SCREEN-PRINTED ELECTRODES WITH A CERAMIC SUBSTRATE WITH THE SPE CONNECTOR CAN CAUSE DAMAGE TO THE CONNECTOR.

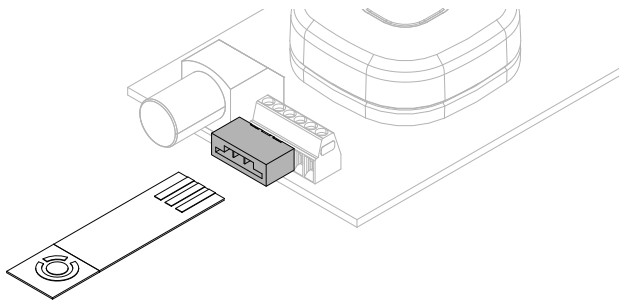

4.2 Universal adapter with velcro strap

The supplied universal adapter with velcro strap allows for soldering on a small connector or wires to any kind of electrochemical sensor or cell.

The SPE connector can be soldered directly onto the exposed pads, as shown here:

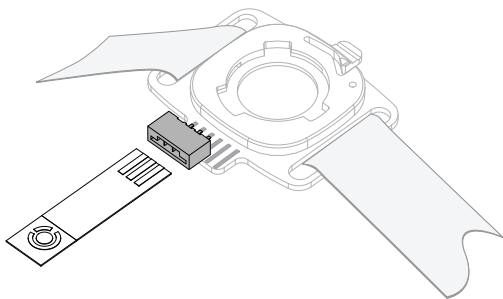

5 Pin-out

The pogo pins at the bottom of the Sensit Wearable have the following functions:

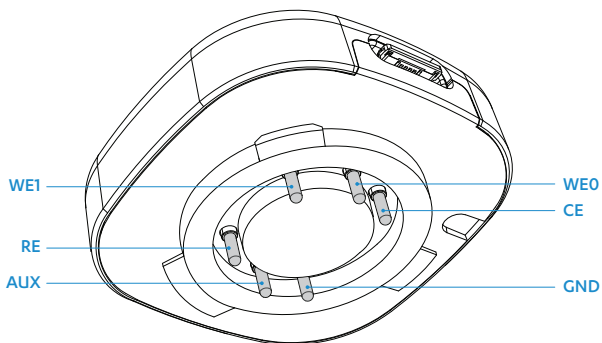

Pin	Function
WE0:	Main Working Electrode / WE1
WE1:	Second Working Electrode / WE2 / Bipotentiostat
CE:	Counter Electrode
RE:	Reference Electrode
AUX:	Reserved (see next section)
GND:	Analog Ground

5.1 Auxiliary (AUX) pin

The AUX pin is connected to an internal NTC temperature sensor by default. In case this pin is required to make a connection to an external signal the following specifications are valid for the pin:

Input range: 0V - 2.8 V (16 bits)

Resolution: 56 μ V

Please note that this requires an in-factory modification. In the default hardware configuration this pin should be regarded as “reserved”.

THE AUX PIN IS SET AS “RESERVED” IN THE STANDARD
HARDWARE CONFIGURATION.
USING THIS POGO PIN REQUIRES AN IN-FACTORY
MODIFICATION.

6 Technical specifications

The Sensit Wearable has the following specifications:

General

- dc-potential range -1.2 V to +2 V
- compliance voltage -2.0 V to +2.3 V
- maximum current ± 3 mA
- max. data acquisition rate 1000 samples/s

Potentiostat (controlled potential mode)

- applied potential resolution 395 μ V
- applied potential accuracy $\leq 0.2\% \pm 1$ mV offset
- current ranges 100 nA, 1 μ A, 6 μ A, 13 μ A, 25 μ A, 50 μ A, 100 μ A, 200 μ A, 1 mA, 5 mA
- measured current resolution 0.006% of CR (5.5 pA on 100 nA range)
- measured current accuracy $< 0.5\%$ of current $\pm 0.1\%$ of range

FRA / EIS (impedance measurements)

- frequency range 16 mHz to 200 kHz
- ac-amplitude range 1 mV to 250 mV rms, or 708 mV p-p

Electrometer

- electrometer amplifier input > 1 T Ω // 10 pF
- bandwidth 250 kHz

Bipotentiostat

- modes
 1. WE2 at fixed potential (E offset vs RE1)
 2. WE2 scanning (E offset vs WE1)
- max. potential WE2 $\Delta E(\text{WE1}) + \Delta E(\text{WE2}) < 1.6 \text{ V}^1$

6.1 EIS accuracy contour plot

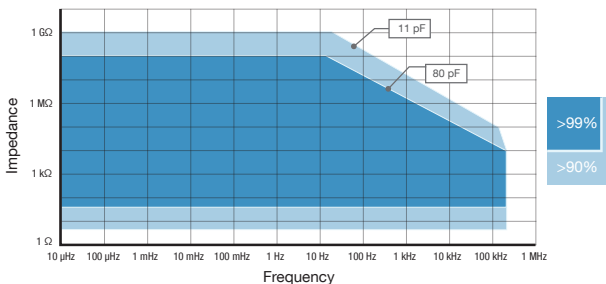

The accuracy contour plot was determined under lab conditions and should be used for reference purposes. Please note that the true limits of an impedance measurement are influenced by all components in the system, e.g. cables, the environment, and the cell.

¹ If your main WE1 is scanning from -0.5V to +0.5V, the WE2 can only have a maximum offset of 0.6V.

7 First Measurement

This section describes how to perform a first measurement in PStTrace 5. Make sure to use the latest version of PStTrace 5, that was supplied with the Development Kit.

Step 1: Prepare the connections

- Mount the Sensit Wearable to the mounting bracket on the Development PCB.

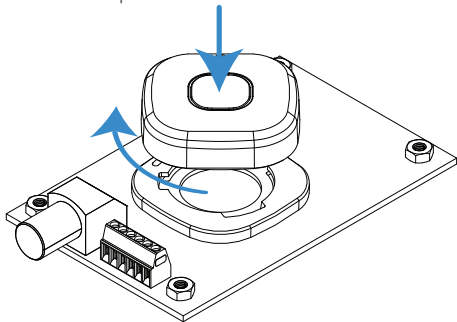

- Connect the cell cable and the USB-C cable.
- Connect the USB-C cable to the PC.
- Switch on the Sensit Wearable.

Step 2: Connecting the Dummy Cell

Connect the cell cable leads to the Dummy Cell using the crocodile clips. Connect the RE and CE pads to the corresponding leads and connect WE (red) to the “WE B” pad. This is a simplified Randles circuit. See the image on the next page as reference. The other leads remain unconnected.

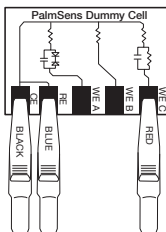

Step 3: PStace

- Run PStace 5
- Connect to the Sensit Wearable using the connection box in the upper left corner of the main window.
- Open the file "Sensit Dummy EIS.psession" found in the folder "EIS examples".

Step 4: Run the measurement

- Start the measurement by clicking the triangular start button at the top of the main window:

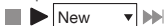

- The resulting Nyquist plot should be similar to the loaded data.

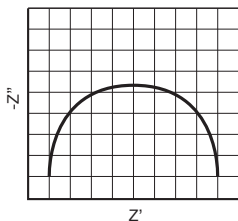

Step 5: Equivalent Circuit Fitting

The EIS data can be fitted to the circuit shown here. Use the Equivalent Circuit Fitting tool in PSTrace.

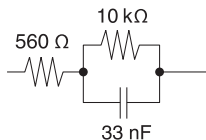

More about EIS measurements

- For an introduction to EIS measurements, see the PSTrace Manual or in-program Help chapter 1, section: “First EIS measurement on the Dummy Cell”
- For more information regarding the Sensit Wearable’s limitations with EIS measurements, please refer to the PSTrace Manual chapter 4, section: “Limitations for EIS on EmStat Pico”
(The Sensit Wearable hardware functions similarly to an EmStat Pico.)

8 Troubleshooting

Your instrument can be tested by using the test sensor or dummy cell supplied with the instrument.

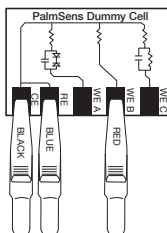

The easiest way to verify the functioning of your instrument is to use the “WE B” circuit, which consists of a resistor with a value of 10 k Ω with a max deviation of 0.1%. The WE lead is connected to one side and both RE and CE to the other side of the resistor. Any of the electrochemical techniques can be applied. The current response obtained with a resistor with value R is equal to the applied potential or potential pulse divided by the value of R. So, if a potential of 0.5 V is applied on a resistor of 10 k Ω , the obtained current should be 0.5 V / 10 k Ω = 50 μ A.

Contact PalmSens BV if the problems are persistent:

info@palmsens.com

Report the problems as detailed as possible. Please include photos and data files if possible.

9 Maintenance and compliance

9.1 Battery

Sensit Wearable battery is a UL, IEC and UN IATA recognized cell. The typical estimated life of the Lithium-Ion battery is about two to three years or 500 charge cycles, whichever occurs first. One charge cycle is a period of use from fully charged, to fully discharged, and fully recharged again. Consider a two-to-three-year life expectancy for batteries that do not run through complete charge cycles.

Rechargeable Lithium-Ion batteries have a limited life and will gradually lose their capacity to hold a charge. This loss of capacity (aging) is irreversible. As the battery loses capacity, the length of time it will power the product (run time) decreases. Lithium-Ion batteries continue to slowly discharge (self-discharge) when not in use or while in storage.

The battery in the Sensit Wearable cannot be replaced.

The use of an unauthorized battery may compromise safety, pose a risk of fire, and result in irreversible damage to the device.

9.2 Temperature compliance

Our instruments are designed for indoor use at ambient temperatures between 0 °C and 45 °C. All the components of the Sensit Wearable (except the battery) are rated to the industrial temperature standard of -40 °C to +85 °C.

The battery of the Sensit Wearable is rated -20 °C to +60 °C when discharging 0 °C to +45 °C when charging.

9.3 Humidity compliance

PalmSens instruments have not been tested in high humidity environments.

Elevated humidity however may cause measurement errors if condensation forms on the electronics. This affects measurements in the nA ranges or lower. Prolonged exposure to a condensing environment may severely decrease the life expectancy of the instrument and void its warranty.

9.4 Temperature drift

PalmSens instruments are calibrated at 21 °C. The most sensitive components of the instrument have temperature drift of 50 ppm. For instance at 1 °C or 41 °C, measurement drift of up to 0.1% may be experienced.

9.5 Atmospheric pressure

PalmSens instruments are not intended for use in safety-critical applications.

9.6 Cleaning

Make sure to disconnect your instrument from any cell or power source, if applicable, prior to cleaning. Use a cloth lightly dampened with either clean water or water containing a mild detergent to clean the outside of the instrument. Alternatively, you can use isopropyl alcohol. Avoid using a wet rag and prevent any fluids from entering the instrument. It is crucial not to immerse the instrument in any cleaning solution.

9.7 Periodic calibration and preventive maintenance

PalmSens instruments are designed in a way that eliminates the need for periodic calibration. While not mandatory, PalmSens does provide a calibration service for users with specific demands such as QC/ISO purposes. This service includes a new calibration certificate.

It's important to note that PalmSens instruments do not require preventive maintenance, further simplifying their use and reducing the overall maintenance demands on users.

9.8 Service and repair

Your Sensit Wearable contains no user-serviceable parts internally. Any service or maintenance needs should be directed to a qualified service technician employed by PalmSens BV. Attempting to access or modify internal components without proper expertise may result in additional damage to the instrument and void warranties. It is recommended to rely on authorized service personnel for any required maintenance or repairs.

9.9 RoHS Compliance

All instruments from PalmSens have been built using lead free components and lead-free solder. They are in compliance with the European RoHS initiative.

10 Links and tips

- See the product page www.palmsens.com/senwb for all latest application notes, technical information and software updates.
- Tera Term is an open source terminal for making a direct serial connection to the Sensit Wearable. This is useful for sending custom MethodSCRIPTs. See also section “MethodSCRIPT: Tips & Tricks” on our website.
- The mounting bracket is available as a STEP file on the product page. The file is suitable 3D printing or as design reference for your bespoke skin patch design.
- Other technical documentation for designing your bespoke skin patch can also be found on the product page.

Appendix A - EU Declaration of conformity



Hereby, PalmSens BV declares that its Sensit Wearable is in conformity with the Radio Emissions Directive 2014/53/EU (RED) and applicable standards listed below:

Health & Safety

- EN 62479
- EN 61010-1

EMC

- EN 61326-1
- EN 301 489 parts 1 & 17

Efficient Usage of Radio Spectrum

- EN 300 328

Manufacturer: PalmSens BV

Address: Vleugelboot 22, 3991 CL Houten, The Netherlands

Date: 5th July 2024

A handwritten signature in black ink, appearing to read 'C.J. van Velzen', written over a horizontal line.

C.J. van Velzen, CTO

Appendix B - EU Waste Electrical and Electronic Equipment (WEEE) directive



Important Information for Correct Disposal of the Product in Accordance with the WEEE Directive

This symbol on the product or its packaging indicates that this product shall not be treated as household waste. Instead, it should be taken to an applicable collection point for the recycling of electrical and electronic equipment. By ensuring this product is disposed of correctly, you will help prevent potential negative consequences for the environment and human health, which could otherwise be caused by inappropriate waste handling of this product.

For more detailed information about recycling of this product, please contact your local city office, your household waste disposal service, or the shop where you purchased the product.

Instructions for Proper Disposal

Do not dispose of this product as unsorted municipal waste. Hand the product over to an authorized collection facility for recycling.

Remove the battery inside before disposal and dispose separately in accordance with local regulations.

Appendix C - Sensit Wearable for OEM

The Sensit Wearable circuit board is also available for OEM purposes. Contact us to discuss the possibilities.

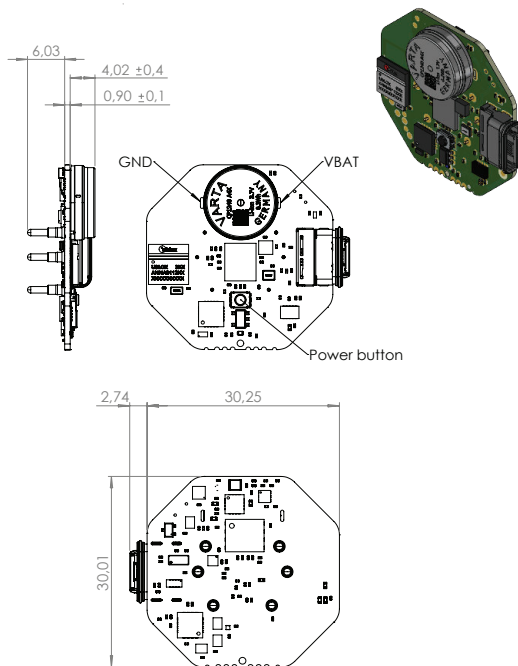

See also: www.palmsens.com/senwb

Appendix D - Mounting bracket technical drawings

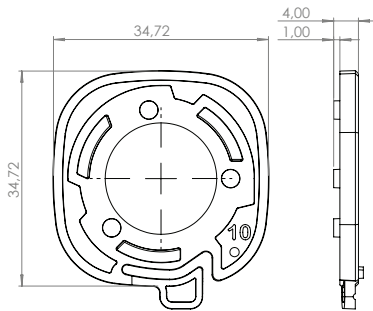

Mounting holes (TopView)

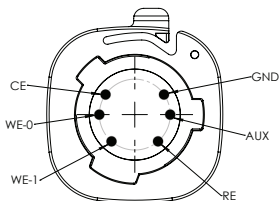
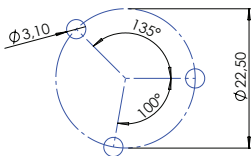

Pin/Pad designations (TOP VIEW)

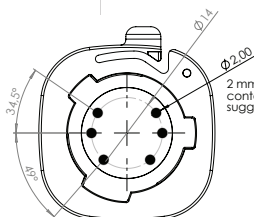

Pads dimensions (TOP VIEW)



2 mm diameter for the contact pads is the suggested minimum

See also: www.palmsens.com/senwb

Published by

PalmSens BV
Vleugelboot 22
3991 CL Houten
The Netherlands
© 2024 PalmSens BV
All rights reserved.

