

EMSTAT4 MUX™

Operator's Manual

Version 04-2026-010



If you have problems

First make sure to check the “Troubleshooting” section in this document and the Knowledge Base on our website: www.palmsens.com/knowledgebase/
This page contains support information on installation, software updates, and training.

Please make sure your software and firmware are up-to-date.



In case of persistent problems:

Use the contact form: www.palmsens.com/contact/

Give us a call: +31 30 2459211

Or send an email: info@palmsens.com

Try to describe the problem as detailed as possible. Sending us the relevant method files, data files, screenshots, pictures of the samples and connections can be helpful.

Please include your instrument model and serial number, as well as any applicable software and firmware version you are using.

Limited Warranty

Unless stated otherwise, PalmSens BV provides a limited warranty of three (3) years from the date the product is transferred to the buyer. During this period, PalmSens BV guarantees that the product is free from defects in materials and workmanship. Moreover, PalmSens BV ensures that the product conform to the specifications described in published datasheets or, if applicable, the user manuals available at the time of purchase.

PalmSens BV’s only responsibility under this warranty is to repair or replace the product. Alternatively, PalmSens BV may choose to credit the buyer’s account for the returned item. However, PalmSens BV has the right to reject the claim if it determines that the warranty does not apply.

Products returned to PalmSens BV for warranty service must be shipped at the buyer’s expense, while PalmSens BV will cover the return shipping costs. The warranty is valid only if full payment for the product has been received.

See our website for more detailed information:

www.palmsens.com/terms-and-conditions/

Disclaimers

PalmSens BV is not liable for any direct, indirect, incidental, or consequential damages resulting from the use or misuse of its instruments, including but not limited to:

- Damage to the instrument caused by improper handling, unauthorized modifications, or use outside the recommended specifications.
- Malfunction or incorrect results due to improper sample preparation, contamination, or incorrect experimental setup.
- Loss of data or research results caused by software crashes, hardware failures, or power interruptions.
- Personal injury or property damage resulting from incorrect wiring, exposure to hazardous chemicals, or misuse of electrical connections.

Results obtained using PalmSens instruments depend on experimental conditions, sample properties, and user expertise. Users are responsible for verifying the validity of their data.

Changes in specifications and typing errors reserved. Every effort has been made to ensure the accuracy of this document. However, no rights can be claimed by the contents of this document.

By using PalmSens instruments, the user acknowledges and accepts these limitations and responsibilities.

See Appendix A for CE declaration of conformity.

Copyrights

EmStat4 MUX Operator's Manual.

Copyright ©2024-2026, PalmSens BV, all rights reserved.

PSTrace, MultiTrace, Nexus, PalmSens, EmStat, MultiEmStat and Sensit are trademarks of PalmSens BV.

No part of this document may be copied or reproduced in any form without the prior written consent of PalmSens BV.



Contents

1	Introduction.....	7
1.1	The scope of this manual.....	7
1.2	About the EmStat4 MUX.....	8
1.3	Supported Switching Modes.....	8
2	Installing the EmStat4 MUX.....	9
2.1	Preparing for operation.....	9
2.2	Adding more multiplexers.....	9
3	Operating the EmStat4 MUX.....	11
3.1	Connectors.....	11
3.2	Connecting and powering.....	11
3.3	Cell connectors and indicators.....	12
3.4	Connecting cells to the instrument.....	13
3.5	Cell connector pin-outs.....	15
3.6	Auxiliary port (AUX).....	16
3.7	Cell configurations.....	17
3.8	Changing multiplexer configuration in software.....	18
3.9	Alternate mode.....	19
4	Specifications.....	21
5	Troubleshooting.....	23
5.1	Verifying your potentiostat.....	23
5.2	Noise troubleshooting.....	24
6	Maintenance and compliance.....	25
6.1	Temperature compliance.....	25
6.2	Humidity compliance.....	25
6.3	Temperature drift.....	25
6.4	Atmospheric pressure.....	25
6.5	Cleaning.....	25
6.6	Periodic calibration and preventive maintenance.....	25
6.7	Service and repair.....	26
6.8	RoHS Compliance.....	26
A.	EU Declaration of Conformity.....	27
B.	EU Waste Electrical and Electronic Equipment (WEEE) Directive.....	28

1 Introduction

1.1 The scope of this manual

This manual covers the handling, characteristics, troubleshooting, and other practical information regarding the hardware specifics of the EmStat4 MUX, as well as maintenance and compliance.

Please refer to the **Quick Installation Guide** that was supplied with the instrument for instructions on installing the instrument and the software. Additionally, the section **Getting Started** in the digital **PSTrace Manual**, that is installed with the software, provides detailed instructions for conducting first measurements with your instrument.



Initial setup and basic operational instructions for conducting initial measurements are detailed in the “Quick Installation Guide” supplied with the instrument.

The PSTrace Manual is an in-depth document covering not only the PSTrace software but also the hardware limitations for each technique supported by the instrument. It is written to give you a full understanding of both the software and hardware aspects, making sure you're well-equipped to use all the functionalities of the EmStat4 MUX.



Figure 1 The EmStat4 MUX

1.2 About the EmStat4 MUX

The EmStat4 MUX is a very compact combination of our MUX8-R2 multiplexer with an integrated EmStat4 LR potentiostat module.

The multiplexer allows to increase productivity by automatically switching between multiple electrochemical cells each with their own WE, RE, CE and Sense electrodes. Additionally, it can be employed to automatically switch the active Working Electrode (WE) and Sense (S) within a cell containing multiple WEs, while utilizing a shared RE/CE.

If more channels are required, one or more additional multiplexer(s) model MUX8-R2 can be stacked to the EmStat4 MUX for a total of up to 128 channels.

1.3 Supported Switching Modes

EmStat4 MUX can work in two different modes, named as *consecutive* and *alternate*. In *consecutive* mode each channel is set before the next measurement starts. After the measurement is finished, the multiplexer switches to the next channel, until the last channel is reached. In *alternating* mode, the channels are quickly scanned during each data point giving a virtual-simultaneous measurement across the selected channels.

For the alternate mode to work properly, the applied signal must not change with time during the data point acquisition. Therefore, only a few techniques are available in alternate mode.

Refer to section for more details.

2 Installing the EmStat4 MUX

2.1 Preparing for operation

If the EmStat4 MUX was taken from a cold location into a warm humid location, water vapor might condense at the inside. If this is the case, it is important to leave the instrument in the room for at least an hour before connecting it to the power supply.

2.2 Adding more multiplexers

The EmStat4 MUX has a Link connector which can be used to daisy chain to a MUX8-R2 multiplexer, expanding the number of channels. Remove the latching screws of all Input connectors of the additional MUX8-R2's.

Connect the Link connector of the EmStat4 MUX to the Input connector of the additional MUX8-R2 multiplexer. If more than one multiplexer is added, connect the Link of each additional MUX8-R2 multiplexer to the Input of the next MUX8-R2 multiplexer in the stack. Daisy-chain cables are available from PalmSens BV.

In case more than two multiplexers are added to the stack of multiplexers, additional power is required. It is advised to connect every third multiplexer added to the stack of multiplexers to a USB-C power source, as illustrated by Figure 2.

When supplying power to additional multiplexers, use short, shielded USB-C cables where possible, as long cable runs or unshielded cables can increase susceptibility to electromagnetic interference.

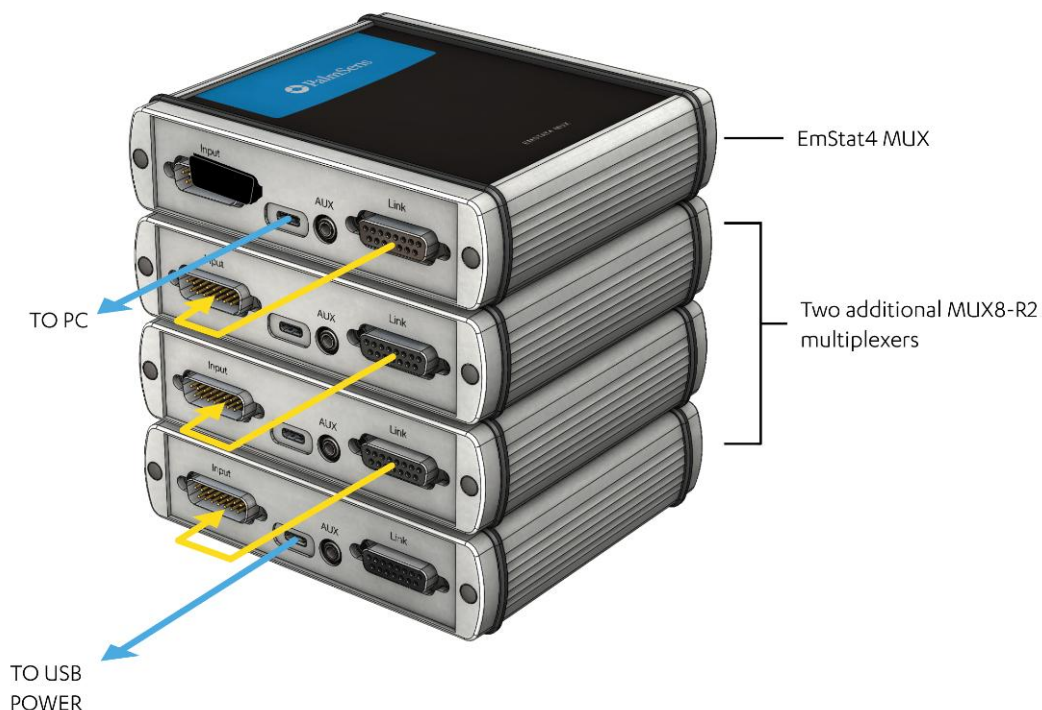

Figure 2 - A daisy-chained stack of MUX8-R2 multiplexers



It is advised to connect every third multiplexer added to the stack of multiplexers to a USB-C power source. This can be a vacant USB port of a PC, or a port on a powered USB hub, for instance.



Figure 3 - The Input and Link connectors on the EmStat4 MUX

A maximum of 16 multiplexers can be connected in a daisy chain, giving a maximum of 128 channels. The PSTrace software detects automatically how many multiplexers are daisy chained and shows the available number of channels in the user interface.

3 Operating the EmStat4 MUX

3.1 Connectors

The EmStat4 MUX has the following connectors:

Table 1 - EmStat4 MUX connectors

Connector	Function
Input	Not used in model EmStat4 MUX.
AUX	Can be used to control an external switch or stirrer or to measure an auxiliary input like temperature.
Link	Connects to Input of next multiplexer, for daisy-chaining multiple multiplexers.
USB-C	For providing extra power in case more than two multiplexers are connected to a single instrument.
Channel 1-4	Connects to WE, S, RE and CE of channels 1-4.
Channel 5-8	Connects to WE, S, RE and CE of channels 5-8.



The Input connector is normally used for daisy-chaining and does not have a function in the EmStat4 MUX.

More details about the connectors are explained in the sections below.

3.2 Connecting and powering

The EmStat4 MUX is powered and controlled directly by means of a standard USB-C cable. The instrument does not have a power switch or any other type of switch or button.



Figure 4 - The USB-C port on the EmStat4 MUX

The blue Power LED (see figure below) will be illuminated as soon as the instrument is powered.



Figure 5 - The Power LED on the EmStat4 MUX

3.3 Cell connectors and indicators

The EmStat4 MUX has two D-SUB (DB-25) connectors for connecting to the cells. See Figure 6.



Figure 6 - Two connectors for connecting eight electrochemical cells

Each D-SUB connector contains pins for connecting four cells, each having its own Working Electrode (WE), Sense Electrode (S), Reference Electrode (RE) and Counter Electrode (CE). The pin-out of each connector is found in the next section.

Every cell has a LED indicator which shows a red color when the channel is active. See the figure below for an example.



Figure 7 - Channel three being the active channel on the EmStat4 MUX



Every cell has an LED indicator which shows a red color when the channel is active.

3.4 Connecting cells to the instrument

PalmSens BV provides different options for connecting cells through the D-SUB connectors. The default option is two cables with DB25 connectors which split in four standard 1 m PalmSens cell cables.

Although the EmStat4 MUX is based on the EmStat4 LR hardware, it includes Sense leads to enhance measurement accuracy, particularly at higher current levels. The Sense lead improves potential measurement precision by compensating for the ohmic drop caused by cables and internal circuitry between the amplifiers and the sample. This compensation becomes especially relevant with the multiplexer, as it introduces additional signal paths not present in single-channel devices. The separate Sense lead is particularly beneficial when working in the 1 mA and 10 mA current ranges, while its impact is negligible at lower ranges. For information on configuring combined Sense connections, refer to section 3.8.

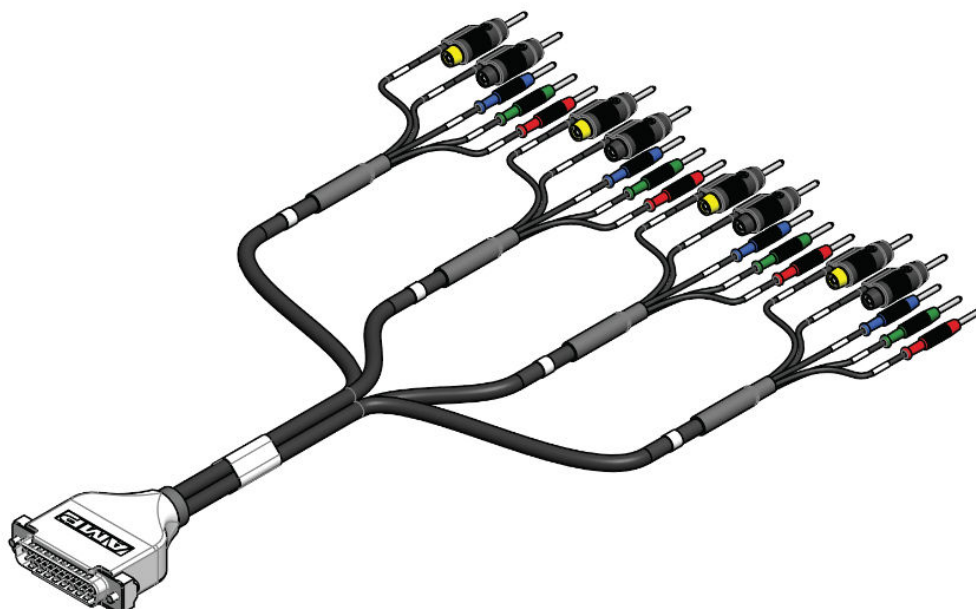

Figure 8 - Standard EmStat4 MUX cable provided by PalmSens (length not to scale)



The stackable 2 mm pin connectors with the yellow ring, labeled "S#" is the Sense lead and must be connected along with the WE, except for 4-electrode systems.

For other cell connection options, including an adapter to screen-printed electrodes, see the instruments page on our website.

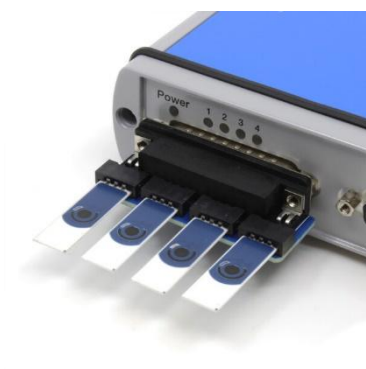
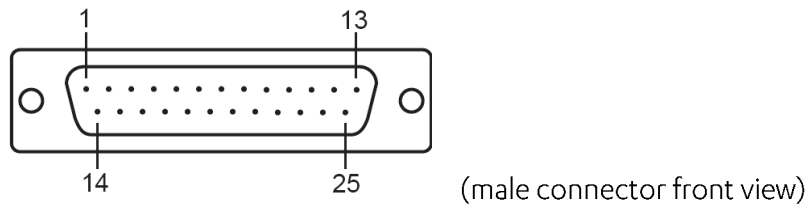

Figure 9 - An adapter for screen-printed electrodes for the EmStat4 MUX

3.5 Cell connector pin-outs



The table below shows the pin-out for channel 1-4.

Table 2 - Channel 1-4 connector pin-out

Pin	Function	Pin	Function	Pin	Function
1	CE4	11	RE1	21	AGND
2	RE4	12	RE_SHIELD1	22	SENSE2
3	RE_SHIELD4	13	Not used	23	WE1
4	CE3	14	WE4	24	AGND
5	RE3	15	AGND	25	SENSE1
6	RE_SHIELD3	16	SENSE4		
7	CE2	17	WE3		
8	RE2	18	AGND		
9	RE_SHIELD2	19	SENSE3		
10	CE1	20	WE2		

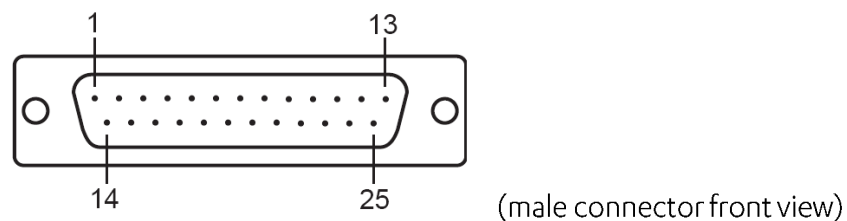

The table below shows the pin-out for channel 5-8.

Table 3 - Channel 5-8 connector pin-out

Pin	Function	Pin	Function	Pin	Function
1	CE8	11	RE5	21	AGND
2	RE8	12	RE_SHIELD5	22	SENSE6
3	RE_SHIELD8	13	Not used	23	WE5
4	CE7	14	WE8	24	AGND
5	RE7	15	AGND	25	SENSE5
6	RE_SHIELD7	16	SENSE8		
7	CE6	17	WE7		
8	RE6	18	AGND		
9	RE_SHIELD6	19	SENSE7		
10	CE5	20	WE6		



The Channels 1-4 and Channels 5-8 connectors have the same pinout, so a cell cable or sample connector will always work for both ports.

3.6 Auxiliary port (AUX)

The EmStat4 MUX auxiliary port (see Figure 10) provides access to the remaining auxiliary pins not occupied by the multiplexer. These pins can be used to connect accessories such as a temperature sensor or a stirrer switch controller, both available from PalmSens BV.



Figure 10 - The EmStat4 MUX auxiliary port

A cable with stripped ends for the auxiliary port is available as an optional item from PalmSens BV.

The diagram below shows the connections available in the auxiliary (AUX) port.

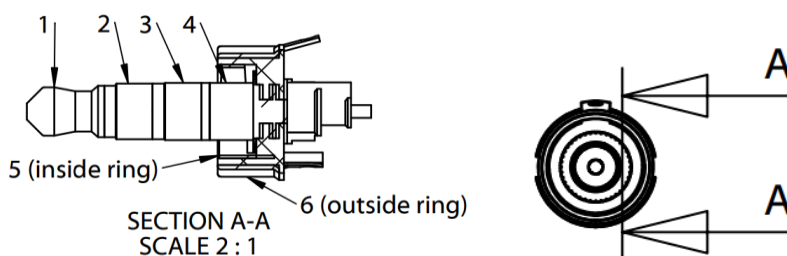

Figure 11 - Auxiliary port pin out

The lead colors in the table below correspond to the standard cable from PalmSens BV.

Table 4 Auxiliary port pin assignment and corresponding lead color

Ring	Lead color	Function
1	Red	Not used
2	Black	D0 (digital output)*
3	Yellow	Analog Input
4	White	D1 (digital output)*
5	Green	GND
6	Blue	5V

*The D0 and D1 outputs are not directly connected to the D0 and D1 pins of the potentiostat. They are intended for use with the stirrer only and may not function as expected in other applications.

3.7 Cell configurations

The EmStat4 MUX is designed to connect up to 8 channels (or up to 128 channels when using daisy-chained MUX8-R2 multiplexers). It supports 2-, 3- and 4- electrode sensors or cells.

The multiplexer can be used with different electrode or sensor configurations (see Figure 12):

- Eight separate cells or sensors each with a working (+sense), reference and counter electrode.
- Eight separate cells or sensors each with a working (+sense) and combined reference and counter electrode.
- Cell or sensor array with eight working electrodes (+sense) sharing one reference and one counter electrode.
- Cell or sensor array with eight working electrodes (+sense) sharing one combined reference/counter electrode.

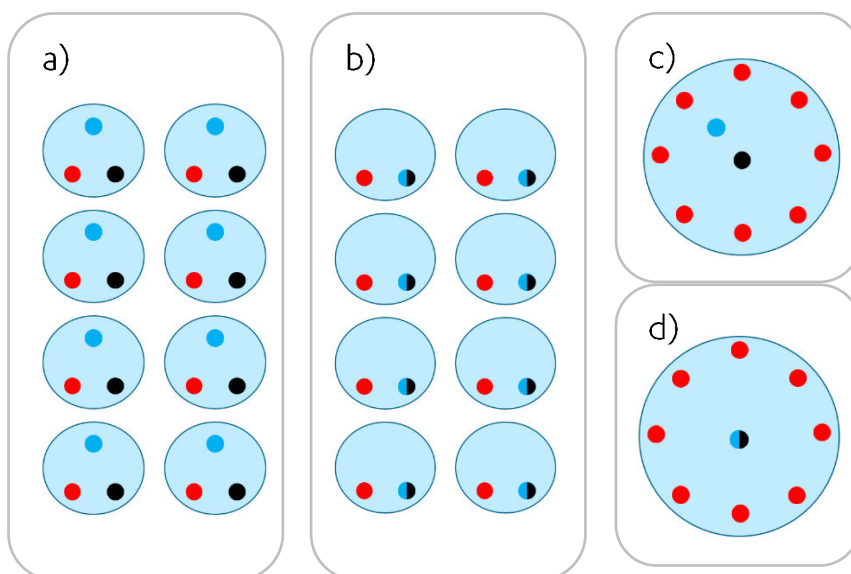

Figure 12 - Possible arrangements for multiple electrodes; small circles mean red = WE+Sense, black = CE, blue = RE

In all configurations the cells can be multiplexed, leaving the non-selected working electrodes either at open circuit (individually floating) or at Ground potential. The

following section explains how to set the multiplexer for these configurations in software.

3.8 Changing multiplexer configuration in software

The hardware configuration of the multiplexer can be set as part of the measurement settings in our PStace software for Windows.

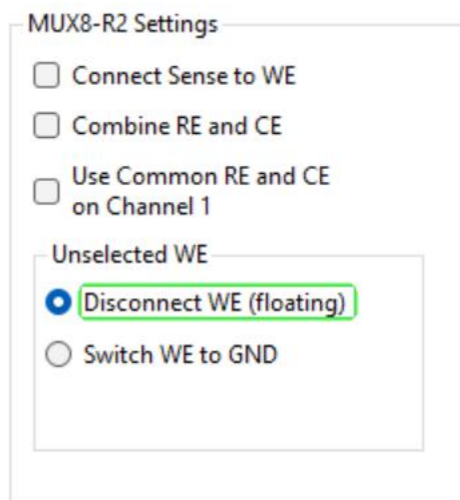

Figure 13 - The MUX8-R2 multiplexer settings in PStace for Windows

The software allows for changing the hardware configuration of the multiplexer by:

- **Connecting Sense to WE:** this setting eliminates the need for stacking WE and Sense leads. We recommend using this setting only when operating below the 1 mA current range. For currents of 1 mA and higher, it is advisable to connect the Sense leads directly to the WE leads at the cable ends. This helps compensate for ohmic drops and ensures accurate potential measurements.
- **Combine RE and CE:** this setting eliminates the need for stacking RE and CE leads, convenient for 2-electrode configuration. Also, it is advisable to check this setting only when operating below the 1 mA current range
- **Use Common RE and CE on Channel 1:** this setting connects the RE and CE (respectively) from all other channels to channel 1. This eliminates the need for merging RE leads and CE leads from multiple channels when working with a cell array.

The **Unselected WE** setting defines what happens with the idle (inactive) working electrodes. You will find two options:

- **Disconnect WE (floating):** this is the standard setting, it simply disconnects the unselected WE leaving them at open circuit.
- **Switch WE to GND:** this setting makes unselected channels to be connected to Ground. Since the active WE is usually at Ground potential, they will follow the same potential as the active (selected) WE vs. active RE.

3.9 Alternate mode

The Alternate mode is a feature developed by PalmSens to enable simultaneous-like measurements. During the execution of alternating multiplexer measurements, all chosen channels will rapidly switch within each measurement interval.

The following techniques support the alternate mode:

- Chronoamperometry
- Zero Resistance Amperometry
- Chronopotentiometry
- Open Circuit Potentiometry
- Electrochemical Impedance Spectroscopy (also Galvanostatic).

It's important to note that this mode is not entirely equivalent to a MultiPotentiostat (PolyPotentiostat) due to hardware constraints. While it can yield a similar response in some cases (e.g., pure resistor), in certain cells, the response may not be suitable.

In the figure below, the potential behavior in each channel for a Chronoamperometry experiment is illustrated.

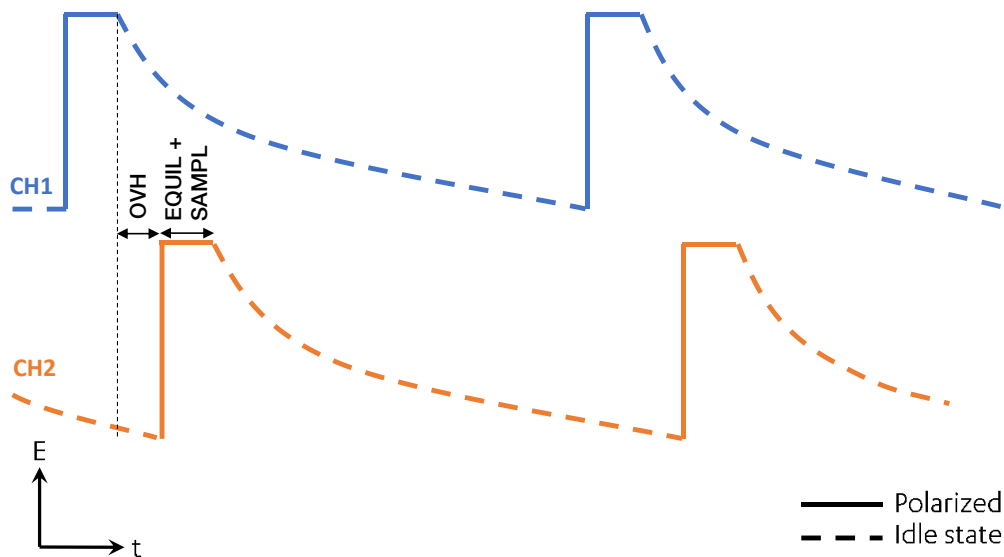

Figure 14 - Example of potential (voltage) behavior for the alternate mode in a typical electrochemical cell running a Chronoamperometry experiment. OVH = overhead, EQUIL + SAMPL = equilibration + sampling.

Each channel is polarized according to the set potential just around the current sampling time. During the 'idle' time when other channels are being switched/measured, the WE potential will go to an idle state. The following scenarios apply according to the setting 'Unselected WE' (see Figure 13):

- If the option is set to 'Disconnect WE (floating)', the potential in the idle state will 'float,' tending to return to an equilibrium state (open circuit potential).
- If the option 'Switch WE to GND' is selected, then the idle potential will be equal to the active WE vs. CE, as the GND has the same potential as the active WE. Note that if you have separate cells, the idle potential will trend to 'floating' anyway, as the CE leads are independent, making it impossible to polarize the idle WE vs. the active GND.



When using individual cells and Unselected WE connected to Ground, the Alternate mode may produce different responses compared to the Consecutive mode. For proper polarization, all Working Electrodes (WEs) must be immersed in the same electrolyte and share a common Reference and Counter Electrode (RE+CE).

Time interval and switching time

For the EmStat4 MUX and (stacked) MUX8-R2, the switching time is 2 ms per channel. When running an alternate mode measurement, the minimum interval time is limited to ensure the cell has time to settle after switching channels. For 1-8 channels selected, the minimum interval is 250 ms, for 9-16 channels (stacked multiplexer) the minimum interval time is 500 ms.

4 Specifications

The following table shows the main specifications for the EmStat4 MUX

Table 5 EmStat4 MUX main specifications

▪ electrodes	WE, S, RE, CE and Ground, 2 mm banana plugs
▪ channels	8 x [WE, S, RE, CE and Ground]
▪ potential range	± 3 V
▪ max. compliance	± 5 V
▪ current ranges	1 nA to 10 mA (8 ranges)
▪ max. current	± 30 mA
▪ on resistance for WE	1.5 Ω typical
▪ charge injection on WE	20 pC typical
▪ leakage current	< 20 pA (5 pA typical) at 25 °C
▪ switching overhead time	2 ms
▪ compliance voltage	± 5 V
▪ max. frequency for EIS	100 kHz when switching WE/S, RE and CE 200 kHz when switching WE/S and RE+CE combined (2-electrode configuration)



Specifications are subject to change, due to regular firmware updates. See the EmStat4 MUX product page on our website for more detailed specifications.

5 Troubleshooting

5.1 Verifying your potentiostat

Your instrument can be tested by using the test sensor or dummy cell supplied with the instrument.

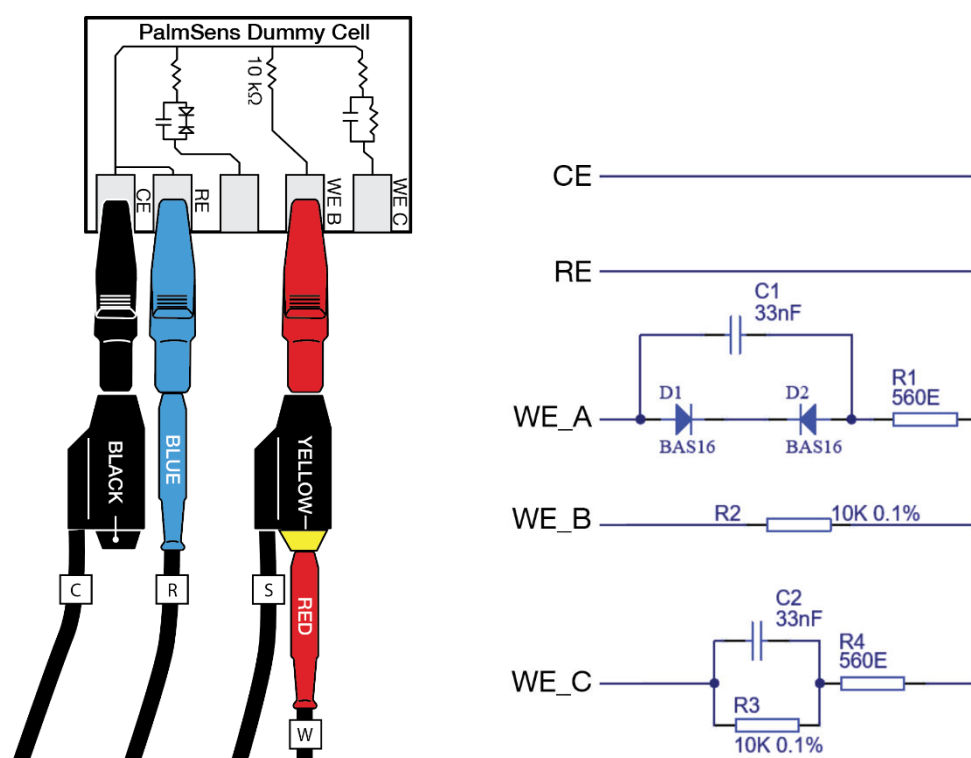

Figure 15 PalmSens Dummy Cell supplied with the EmStat4 series.

The easiest way to verify the functioning of your instrument is to use the “WE B” circuit, which consists of a resistor with a value of 10 kΩ with a max deviation of 0.1%.

The WE+Sense leads are connected to one side and both RE and CE to the other side of the resistor. Use channel one of your EmStat4 MUX and make sure the channel is selected in the Multiplexer settings of the PSTrace software. You can repeat this test for each of the other channels.

Any of the electrochemical techniques can be applied. The current response obtained with a resistor with value R is equal to the applied potential or potential pulse divided by the value of R. So, if a potential of 0.5 V is applied on a resistor of 10 kΩ, the obtained current should be $0.5 \text{ V} / 10 \text{ k}\Omega = 50 \mu\text{A}$.

Contact PalmSens BV if the problems are found: info@palmsens.com and report the problems as detailed as possible.

5.2 Noise troubleshooting

Our instruments are designed with hardware noise suppression filters to reject noise from internal and external sources. If a higher level of noise is your issue, the solving strategies are rather numerous, but the sources for noise are also numerous. Here we describe the most successful and common methods for noise reduction.

To determine the noise levels for your instrument, please refer to section **Measuring the noise level of the instrument** in the PSTrace Manual.

5.2.1 Power grid

Your power grid is usually using an alternating current. This undulating current influences the measured currents. PSTrace have a filter for this mains frequency. In PSTrace, check in the 'Tools' menu under 'General Settings' if the mains frequency is set correctly (50 Hz or 60 Hz).

5.2.2 Electric fields

Our environment is filled with electric fields. Some of them are created by devices around us as side effects or in case of wireless communication on purpose. Although it is a bad idea to measure directly next to an electric arc furnace, it is usually not possible to have a workspace free of electric fields, especially not during point-of-care measurements.

Nearby RF transmitters (Wi-Fi routers, mobile phones, industrial radios) may be interpreted by the instrument as valid electrochemical signals. Measurements performed near such sources may therefore deviate from stated specifications.

A Faraday cage is usually sufficient to create a field-free environment. A metal box or cage out of metal mesh is a good Faraday cage. Even a shield out of aluminum foil can help. Place your electrochemical cell inside the Faraday cage and connect the cage to the ground lead (green) of the potentiostat. The cable delivered with your instrument has an inbuilt shield and should protect your signal outside the Faraday cage. This is one of the most effective methods to reduce noise.

5.2.3 Cables

Cables should not be unnecessarily long, since they act as antennas for noise, but the cable delivered with your instrument has an inbuilt shield and as long as you use the original cable, there is little reason to worry about cable-induced noise.

For optimal electromagnetic compatibility (EMC) and to minimise radiated or conducted interference, PalmSens recommends using only the supplied USB cables provided where possible. Longer or third-party USB cables may behave as antennas and increase susceptibility to external electromagnetic fields, potentially affecting noise levels and measurement performance.

5.2.4 Contacts

Check if the contacts are corroded. If so, remove the stains, for example with sandpaper.

6 Maintenance and compliance

6.1 Temperature compliance

Our instruments are designed for indoor use at ambient temperatures between 0 °C and 45 °C. All the components of PalmSens products (except their batteries) are rated to the industrial temperature standard of -40 °C to +85 °C.

6.2 Humidity compliance

PalmSens instruments have not been tested in high humidity environments.

Elevated humidity may cause measurement errors if condensation forms on the electronics. This affects measurements mainly in the nA ranges or lower. Prolonged exposure to a condensing environment may severely decrease the life expectancy of the instrument and void its warranty.

6.3 Temperature drift

PalmSens instruments are calibrated at 21 °C. The most sensitive components of the instrument have temperature drift of 50 ppm. For instance, at 1 °C or 41 °C, measurement drift of up to 0.1% may be experienced.

6.4 Atmospheric pressure

PalmSens instruments are not intended for use in safety-critical applications. Consequently, the power supplies utilized are not selected based on a specific pressure rating.

6.5 Cleaning

Make sure to disconnect your instrument from any cell or power source, if applicable, prior to cleaning. Use a lightly dampened cloth with either clean water or water containing a mild detergent to clean the outside of the instrument. Alternatively, you can use isopropyl alcohol. Avoid using a wet rag and prevent any fluids from entering the instrument. It is crucial not to immerse the instrument in any cleaning solution.

6.6 Periodic calibration and preventive maintenance

PalmSens instruments are designed in a way that eliminates the need for periodic calibration. While not mandatory, PalmSens does provide a calibration service for users with specific demands such as QC/ISO purposes. This service includes a new calibration certificate.

PalmSens instruments do not require preventive maintenance, further simplifying their use and reducing the overall maintenance demands on users.

6.7 Service and repair

Your PalmSens instrument contains no user-serviceable parts internally. Any service or maintenance needs should be directed to a qualified service technician employed or authorized by PalmSens BV. Attempting to access or modify internal components without proper expertise may result in additional damage to the instrument and voids warranty. It is recommended to rely on authorized service personnel for any required maintenance or repairs.

6.8 RoHS Compliance

All instruments from PalmSens have been built using lead-free components and lead-free solder. They are in compliance with the European RoHS initiative.

A. EU Declaration of Conformity



EU DECLARATION OF CONFORMITY



Certificate number: PSDOC-ES4MUX-A

Manufacturer: PalmSens BV
Address: Vleugelboot 22,
3991 CL Houten,
The Netherlands

This declaration is valid for the following product:

EmStat4 MUX, Portable electrochemical analyser with integrated multiplexer

- USB power and communications
- 2x1 meter cell cable assembly

The object of the declaration described above is in conformity with the Electromagnetic-Compatibility Directive 2014/30/EU (EMCD) and applicable standards listed below:

EMC

- EN 61326-1

This declaration is issued under the sole responsibility of PalmSens BV.

Date: 30th of April 2025

A handwritten signature in black ink, appearing to read "C.J. van Velzen", written over a horizontal line.

C.J. van Velzen, CTO

B. EU Waste Electrical and Electronic Equipment (WEEE) Directive



The pictogram shown above, located on the product(s) and / or accompanying documents means that used electrical and electronic equipment (WEEE) should not be mixed with general household waste. For proper treatment, recovery and recycling, please take this product(s) to designated collection points where it will be accepted free of charge.

Alternatively, in some countries, you may be able to return your products to your local retailer upon purchase of an equivalent new product. Disposing of this product correctly will help save valuable resources and prevent any potential negative effects on human health and the environment, which could otherwise arise from inappropriate waste handling. Please contact your local authority for further details of your nearest designated collection point. Penalties may be applicable for incorrect disposal of this waste, in accordance with your national legislation.

Published by

PalmSens BV
Vleugelboot 22
3991 CL Houten
The Netherlands

© 2026 PalmSens BV
All rights reserved.

