

# EMSTAT 4T™

## Operator's Manual

Version 06-2026-006





## If you have problems

First make sure to check the “Troubleshooting” section in this document and the Knowledge Base on our website: [www.palmsens.com/knowledgebase/](http://www.palmsens.com/knowledgebase/)  
This page contains support information on installation, software updates, and training.

Please make sure your software and firmware are up-to-date.



**In case of persistent problems:**

**Use the contact form:** [www.palmsens.com/contact/](http://www.palmsens.com/contact/)

**Give us a call:** +31 30 2459211

**Or send an email:** [info@palmsens.com](mailto:info@palmsens.com)

Try to describe the problem as detailed as possible. Sending us the relevant method files, data files and screenshots can be helpful.

Please include your instrument model and serial numbers, as well as any applicable software and firmware version you are using.

## Limited Warranty

Except as otherwise provided herein, PalmSens BV warrants to buyer three years from the date title to the product passes (transfer date of goods from seller to buyer), each product sold hereunder will be free of defects in materials or workmanship and will conform to specifications set forth in PalmSens BV’s published data sheets or, where applicable, user manuals for PalmSens BV’s system products in effect at the time title passes.

PalmSens BV’s sole liability and responsibility for products under this warranty is for PalmSens BV to repair or replace any product that is returned to it by buyer or credit buyer’s account for such returned product, provided that PalmSens BV shall have the right to reject any such remedy where PalmSens BV determines that the warranty does not apply. Products returned to PalmSens BV for warranty service will be shipped to PalmSens BV at buyer’s expense and will be returned to buyer at PalmSens BV’s expense. PalmSens BV’s obligation to honor its warranty for a product is contingent upon receipt of payment in full for such product.

See our website for more detailed information:

[www.palmsens.com/terms-and-conditions/](http://www.palmsens.com/terms-and-conditions/)

## Disclaimers

PalmSens BV is not liable for any direct, indirect, incidental, or consequential damages resulting from the use or misuse of its instruments, including but not limited to:

- Damage to the instrument caused by improper handling, unauthorized modifications, or use outside the recommended specifications.
- Malfunction or incorrect results due to improper sample preparation, contamination, or incorrect experimental setup.
- Loss of data or research results caused by software crashes, hardware failures, or power interruptions.
- Personal injury or property damage resulting from incorrect wiring, exposure to hazardous chemicals, or misuse of electrical connections.

Results obtained using PalmSens instruments depend on experimental conditions, sample properties, and user expertise. Users are responsible for verifying the validity of their data.

Changes in specifications and typing errors reserved. Every effort has been made to ensure the accuracy of this document. However, no rights can be claimed by the contents of this document.

By using PalmSens instruments, the user acknowledges and accepts these limitations and responsibilities.

See Appendix A for CE declaration of conformity.

## Copyrights

EmStat4T Operator's Manual.

Copyright ©2024-2026, PalmSens BV, all rights reserved.

PSTrace, MultiTrace, Nexus, PalmSens, EmStat, MultiEmStat and Sensit are trademarks of PalmSens BV.

No part of this document may be copied or reproduced in any form without the prior written consent of PalmSens BV.



# Contents

<b>1</b>	<b>Introduction.....</b>	<b>1</b>
1.1	The scope of this manual.....	1
1.2	About the EmStat4T.....	2
1.3	EmStat4T configurations.....	4
1.4	Modes of operation.....	4
1.5	Accessories .....	5
1.6	Software .....	5
<b>2</b>	<b>Operating the EmStat4T.....</b>	<b>7</b>
2.1	Preparing for operation.....	7
2.2	Switching on and off.....	7
2.3	Charging .....	8
2.4	Connecting via USB.....	8
2.5	Connecting via Bluetooth .....	8
2.6	Touch display .....	9
2.7	Connection Modules.....	10
<b>3</b>	<b>Running measurements.....</b>	<b>13</b>
3.1	Connecting a cell to the potentiostat .....	13
3.2	Using Screen-Printed Electrodes (SPEs) with the EmStat4T.....	16
<b>4</b>	<b>Standalone operation.....</b>	<b>19</b>
4.1	Developing apps .....	19
4.2	Configuring the style and behavior.....	21
<b>5</b>	<b>Specifications.....</b>	<b>25</b>
5.1	System specifications.....	25
5.2	SNS Connection Module pin-out .....	26
5.3	SPE Connection Module pin-out.....	26
<b>6</b>	<b>Battery replacement.....</b>	<b>29</b>
<b>7</b>	<b>Troubleshooting .....</b>	<b>31</b>
7.1	MethodSCRIPT error codes.....	31
7.2	Verifying your potentiostat.....	31
7.3	Noise troubleshooting.....	33
7.4	Firmware updates.....	33
<b>8</b>	<b>Maintenance and compliance .....</b>	<b>35</b>

8.1	Temperature compliance .....	35
8.2	Humidity compliance.....	35
8.3	Temperature drift.....	35
8.4	Atmospheric pressure.....	35
8.5	Cleaning.....	35
8.6	Periodic calibration and preventive maintenance.....	35
8.7	Service and repair.....	36
8.8	RoHS Compliance .....	36
<b>9</b>	<b>Licenses .....</b>	<b>37</b>
<b>A.</b>	<b>EU Waste Electrical and Electronic Equipment (WEEE) Directive .....</b>	<b>38</b>
<b>B.</b>	<b>EU Declaration of Conformity.....</b>	<b>39</b>

# 1 Introduction

## 1.1 The scope of this manual

This manual covers the handling, characteristics, troubleshooting, and other practical information regarding the hardware specifics of the EmStat4T, as well as maintenance and compliance.

Please refer to the **Quick Installation Guide** that was supplied with the instrument for instructions on installing the instrument and the software. Additionally, the section **Getting Started** in the digital **PSTrace Manual**, that is installed with the software, provides detailed instructions for conducting first measurements with your instrument.



Initial setup and basic operational instructions for conducting initial measurements are detailed in the “Quick Installation Guide” supplied with the instrument.

The PSTrace Manual is an in-depth document covering not only the PSTrace software but also the hardware limitations for each technique supported by the instrument. It is written to give you a full understanding of both the software and hardware aspects, making sure you're well-equipped to use all the functionalities of the EmStat4T.



Figure 1 - The EmStat4T SPE (left) and EmStat4T SNS (right)

## 1.2 About the EmStat4T

The EmStat4T is a one-of-a-kind device that functions as a potentiostat, galvanostat, and Electrochemical Impedance Spectroscopy (EIS) analyzer. The battery powered EmStat4T is designed for conducting electrochemical research and can also be used as a standalone reader for specific sensor applications. At its core is the EmStat4M LR potentiostat module it connects wirelessly (via Bluetooth) or via a USB cable to a PC, smartphone or tablet. Additionally, it can function independently using its integrated touch screen.

A visual editor allows users to create programs on the EmStat4T enabling users without programming experience to develop a wizard-style app for specific sensor applications.

The integrated QR and bar code scanner enables users to easily identify sensors via a QR code on the package, which may also include calibration data, an expiry date, and other useful information. It can also provide the EmStat4T and any apps running on it with this sensor-specific data. Backed by an advanced imaging engine, the scanner supports a broad array of 1D and 2D barcode formats, offering precision down to 0.1 mm (4 mil) and a reliable depth of field up to 400 mm. This ensures high-speed, flexible scanning whether the instrument is deployed out in mobile settings, such as point-of-care environments. Additional use cases involve scanning QR codes for operator information or sample data.

The cell connector located on the front of the device is modular, allowing users to easily exchange it for compatibility with specific sensors or cells.

## Features

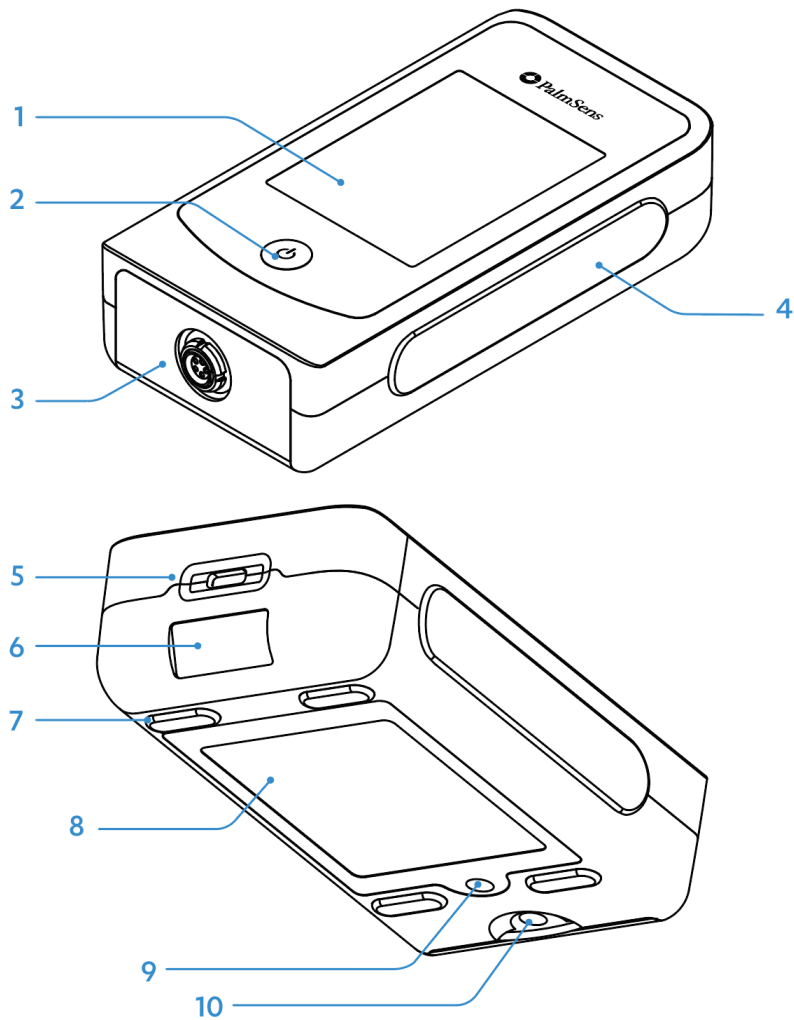

1. Full-color 2.4" 240x320 TFT touch screen
2. Touch power button
3. Exchangeable sensor interface module  
(Either with LEMO connector for cell cable, or with connector for direct use of Screen-Printed Electrodes or SPEs).
4. Rubber grip
5. USB-C port
6. Integrated 1D/2D QR and barcode scanner
7. Rubber feet
8. 3000 mAh Li-Po battery
9. Screw for the battery lid
10. Screw for releasing the sensor interface module

## 1.3 EmStat4T configurations

The EmStat4T is available in different configurations. The EmStat4T is available with or without a license for running Electrochemical Impedance Spectroscopy or EIS. A limited configuration can always be upgraded remotely via software to add functionality. Please contact PalmSens BV, if you are interested in upgrading your EmStat4T.

Two standard options for the front Connection Module are available from PalmSens BV:

1. **Version SNS:** with LEMO connector for use with PalmSens standard 1 meter cell cables
2. **Version SPE:** with connector for Screen-Printed Electrodes with common 0.1" (2.54 mm) pitch and a maximum width of 10 mm.

For options regarding tailored Connection Modules for a bespoke sensor or cell interface, contact PalmSens BV.

The following table shows the available standard configurations of the EmStat4T and the corresponding article codes.

Table 1 - EmStat4T hardware configurations available from PalmSens BV

Article code	Connection Module	EIS capable
C-ES4T-SNS.F0	SNS	NO
C-ES4T-SNS.F1	SNS	YES
C-ES4T-SPE.F0	SPE	NO
C-ES4T-SPE.F1	SPE	YES



A license for Electrochemical Impedance Spectroscopy (EIS) can always be upgraded remotely via software.

## 1.4 Modes of operation

The EmStat4T offers two main modes of operation:

- **Remote Controlled:** In this mode the instrument functions as a standard potentiostat for research purposes, where PSTrace for Windows or the PStouch app for iOS or Android controls the instrument. The connection to the PC, smartphone or tablet can either be via USB or via Bluetooth.
- **Standalone:** With the ability to run apps directly on the device, users perform sensor measurements and analyses without needing a separate computer, making it more portable and convenient.

## 1.5 Accessories

The EmStat4T is supplied standard with the following items.

**EmStat4T SNS & SPE** versions include:

- Shielded USB-C cable to USB-A cable
- Dummy cell
- USB stick with software
- A soft-shell carrying case
- Quick Start document
- Operator's Manual
- Certificate of Calibration

**EmStat4T SNS** version includes additional:

- 1 meter cell cable with 2 mm banana plugs, stackable connectors
- Croc clips for every lead (2 mm)

## 1.6 Software

The EmStat4T is used with PSTrace 5.12 for Windows or later. PSTrace 5.12 comes with the integrated Visual MethodSCRIPT Editor and EmStat4T Configuration tool. For regular operation (Remote Controlled Mode), including running measurements and analyzing data, you can control the EmStat4T directly using PSTrace 5.

For building small apps that run on the EmStat4T, and for configuring the instrument's style and behavior, the following two tools within PSTrace 5 can be used:

1. **The Visual MethodSCRIPT Editor:** The Visual MethodSCRIPT Editor and the EmStat4T configuration tool can be used to program the EmStat4T to run small wizard-style apps. The Visual MethodSCRIPT Editor can be found in the PSTrace main menu under 'Tools' → 'Visual MethodSCRIPT Editor...'

See for more information section **Developing apps** on page 19

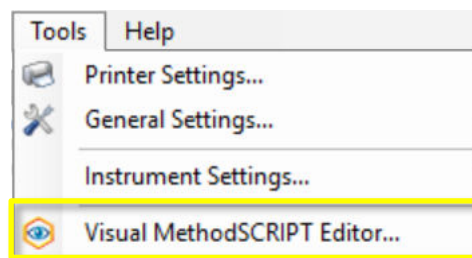

Figure 2 - The Tools menu in PSTrace 5.12 or later for opening the Visual MethodSCRIPT Editor

2. **The EmStat4T Configurator:** The EmStat4T Configurator tool can be found in the main menu under 'Tools' → 'Instrument Settings...' and in the window that appears click the button 'EmStat4T Configurator'.

See for more information section **Configuring the style and behavior** on page 21

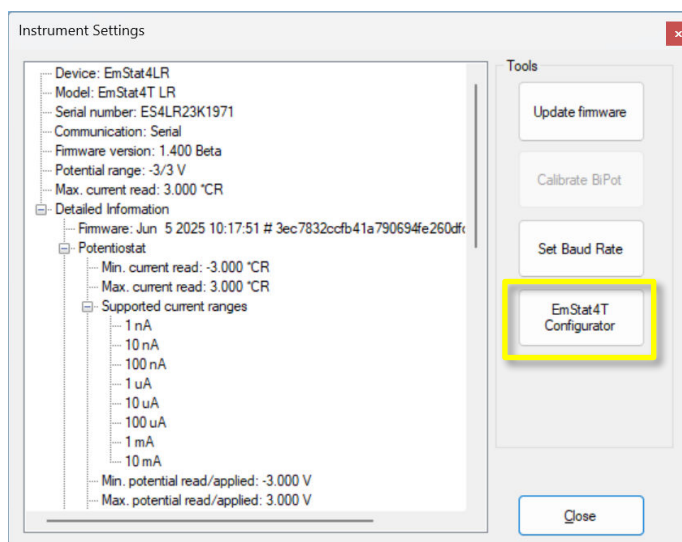

Figure 3 - Opening the EmStat4T Configurator tool in PSTrace 5

## 2 Operating the EmStat4T

### 2.1 Preparing for operation

If the EmStat4T was taken from a cold location into a warm humid location, water vapor might condense at the inside. If this is the case, it is important to leave the instrument in the room for at least an hour before switching it on.

### 2.2 Switching on and off

The power button is located underneath the touch display. To turn on the EmStat4T, touch and hold the power button (no force needed) for two seconds until you hear a short beep, indicating the device is booting. A short melody of three tones sounds when the EmStat4 has fully booted.



Figure 4 - Touching the EmStat4T power button

Touch the power button for three seconds to switch the instrument off again.

## 2.3 Charging

A full charge of the EmStat4T takes about 3 hours. Any USB power source can be used for charging. To charge at maximum speed, ensure you use a charger and cable that can support 1.5 A at 5 V.

## 2.4 Connecting via USB

The EmStat4T has a USB Type-C (USB-C) port and uses the Full-Speed specification. The EmStat4T can be used with any common USB port. Connect the EmStat4T to your computer using the supplied USB-C cable.

For optimal performance, PalmSens recommends using only the shielded USB-C to USB-A (standard rectangular plug) cable supplied as standard with the instrument. Use of other or longer cables may increase susceptibility to electromagnetic interference and may affect measurement performance. Similarly, if feasible, it is recommended to refrain from utilizing a USB hub or docking station.

The USB-C port on the EmStat4T is used for both power and data communication. To operate the device via a PC, make sure PSTrace 5.12 or later is installed, which ensures that the correct drivers are present.

## 2.5 Connecting via Bluetooth

Every EmStat4T has a unique Bluetooth name. The Bluetooth name of the EmStat4T instrument can be found by tapping the hamburger-menu icon  on the display when the instrument is idle.

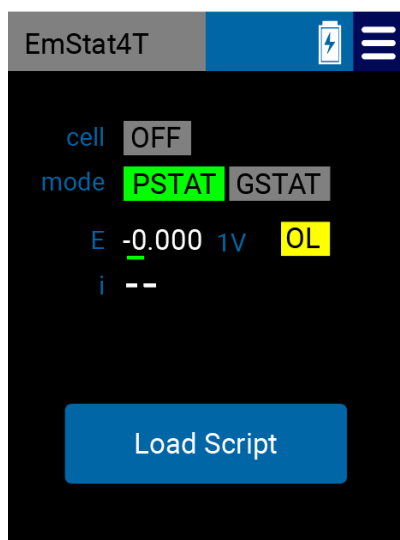

Figure 5 - The hamburger menu (three stacked horizontal lines) is found in the upper right corner of the idle screen

The Bluetooth name always starts with the letters PS, followed by the last 4 characters of its MAC address. For example: PS-6AEF. When connecting with the EmStat4T for the first time, a pairing code will be required by the host. This code is shown on the display of the EmStat4T as "Pair Code" when the host is requesting the code and can be 5 or 6 digits. A random Pair Code is generated every time the device is paired with a host.

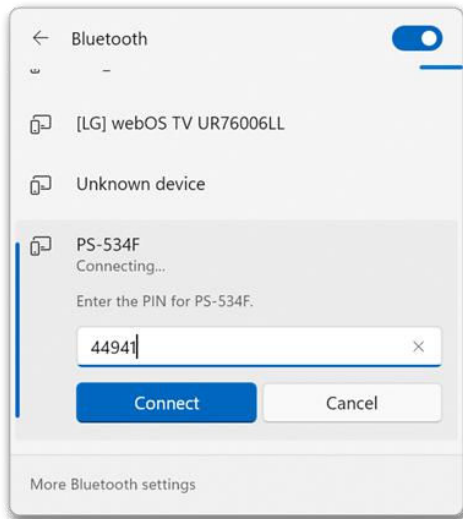

Figure 6 - Entering the Pair Code in Windows 11 when connecting for the first time to the EmStat4T

## 2.6 Touch display

The touch display is meant for use with Wizard-style mini apps which can be designed and generated using the Visual MethodSCRIPT Editor. These apps allow for creating a series of steps the user must follow on the display to run measurements, entering or scanning sensor or user information, doing calculations on the measurement data and presenting and storing the results. This allows for applications where a user or operator is following these steps in an industrial or medical environment carrying out a concentration determination. When the instrument is used in the remote-controlled operation mode, being controlled by a PC or smartphone, the touch screen doesn't serve a purpose apart from showing idle status information and which measurement is running.

When connecting to the USB port of a PC, Bluetooth will switch off automatically unless there is a Bluetooth connection active. This allows the instrument to be charged via the PC while a Bluetooth connection is present. The instrument can also be charged with any other USB-C power source while a Bluetooth connection is present.

## 2.7 Connection Modules

The EmStat4T is supplied with either the SNS Connection Module (Figure 7) for use with the standard 1-meter cell cable provided by PalmSens BV, or the SPE Connection Module (Figure 8) designed for common form-factor screen-printed electrodes.

See also section **SPE Connection Module pin-out** on page 26

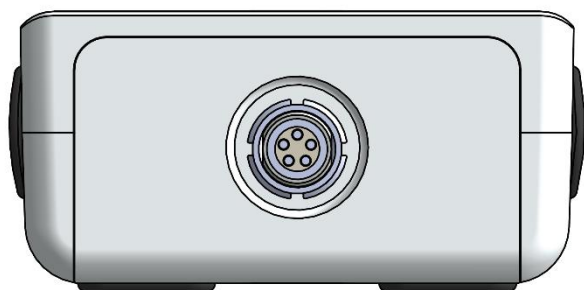

Figure 7 - SNS Connection Module with LEMO connector for 1 meter cell cables

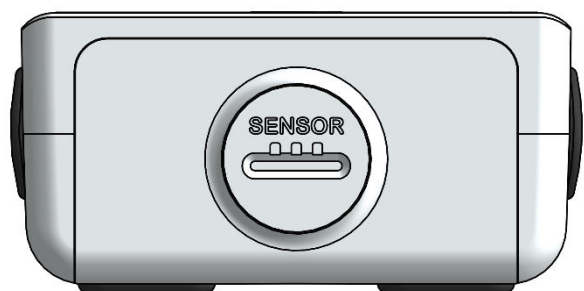

Figure 8 - SPE Connection Module with SPE connector for Screen-Printed Electrodes

In the case of the SNS module, the cell cable is connected to the EmStat4T by means of a LEMO push-pull connector. Make sure the red dot on the connector is facing upwards when plugging the connector into the EmStat4T. See Figure 9.

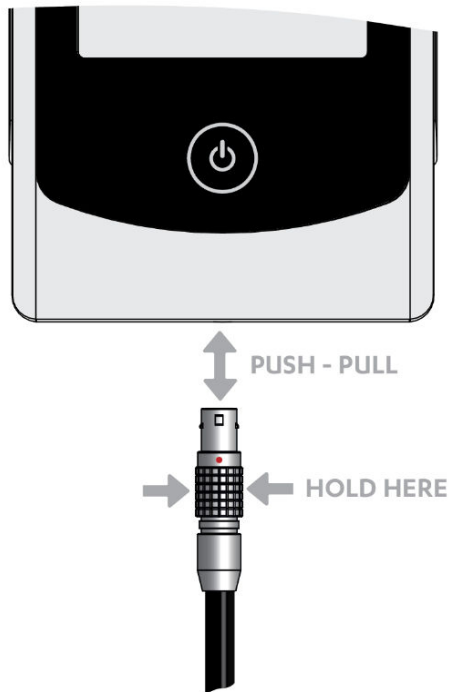

Figure 9 - LEMO push-pull cell connector

### 2.7.1 Replacing the Connection Module

The Connection Module in the front comes standard in two versions, one for use with Screen-Printed Electrodes (SPE version) and one for use with the PalmSens standard 1 meter cell cable. The Connection Module can easily be exchanged by removing the small Philips screw at the bottom side of the device (step 1) and by pushing the Connection Module outwards (step 2). See the figure below.

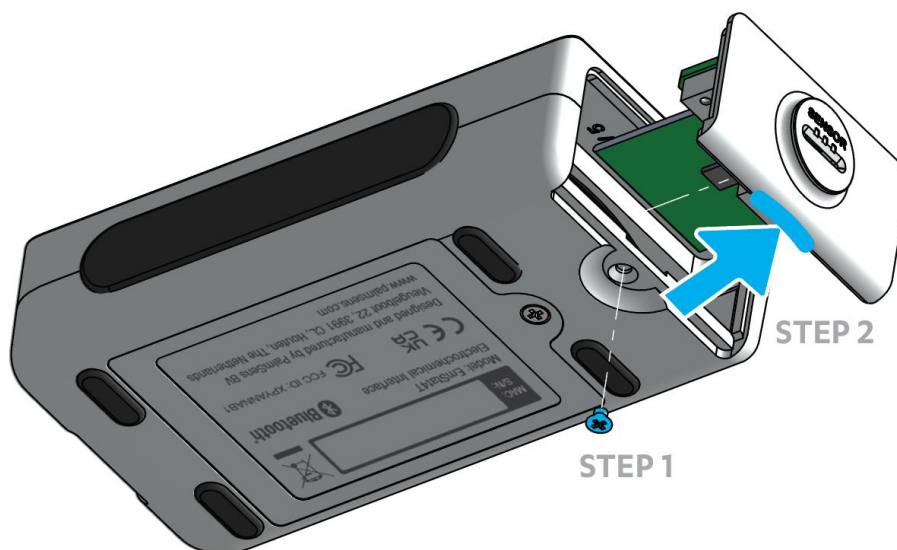

Figure 10 - Replacing the Connection Module



## 3 Running measurements

The PStace software for Windows and the PStouch app for Android allows you to perform all electrochemical techniques supported by the connected EmStat4T instrument. This section outlines how to set up a typical measurement using these applications.

For detailed information on specific techniques, including their options and limitations, please refer to the **PStace Manual**.

This section covers usage in Remote Controlled Mode, where the instrument is operated entirely via PStace or PStouch. In this mode, the EmStat4T's touch screen is not used for control but will display basic status information during measurements.



The options and limitations for each technique are described in the PStace Manual.

More theoretical background information about electrochemical techniques can be found in:

- Christopher M.A. Brett and Ana Maria Oliveira Brett, *Electroanalysis* (Oxford Chemistry Printers, 64) Oxford Science Publications, ISBN-13: 978-0198548164
- Joseph Wang, *Analytical Electrochemistry* 3rd ed, John Wiley & Sons, ISBN-13 978-0471678793

### 3.1 Connecting a cell to the potentiostat

This section describes how to connect the EmStat4T SNS version to an electrochemical cell using the 1-meter cell cable.

The 1-meter cell cable is terminated with 2-mm banana plugs as the lead connectors for the cell / electrodes / sample. Each lead is accompanied by a crocodile (alligator) clip of the same color.



We advise keeping an unused lead connected with its crocodile clip. This practice prevents accidental electrical contacts with the exposed banana plug, minimizing the risk of unintended electrical contacts.

See Table 3 for EmStat4T standard cable lead colors.

Each electrode cable is individually shielded, and the entire cable features an external shielding mesh. The shielding extends up to the beginning of the banana plug. When you are using a Faraday cage, it is advisable to keep the entire banana plugs inside the Faraday cage housing to ensure the cage shields the banana plug.

### 3.1.1 2-electrode cell connection

For a 2-electrode setup, combine the counter and reference electrode leads. The counter electrode plug of the cell cable is stackable, allowing for convenient combination.

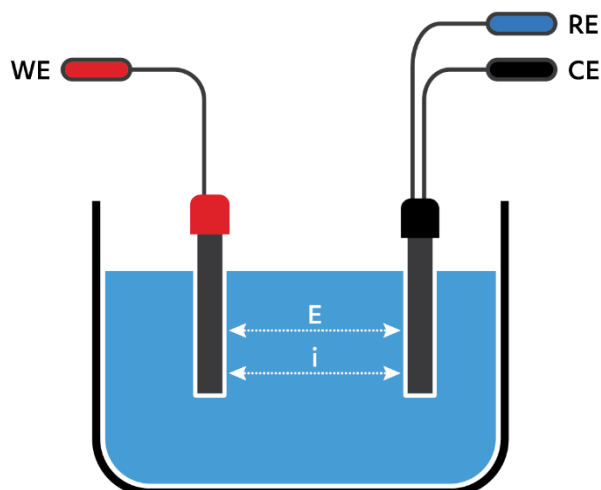

Figure 11 - 2-electrode cell connection

During a measurement in a 2-electrode setup, the potential will be applied between the two electrodes, and the current will flow between the same two electrodes. This means the applied potential includes the potential drop across the working electrode's interface, the potential drop across the solution, and the potential drop across the counter electrode's interface. Any changes at the counter electrode will influence the result. If your counter electrode is expected to be stable during the measurement due to low currents or a short duration of the measurement, you can use this setup almost equivalent to a 3-electrode setup. Otherwise, this setup is only used for applications where the full cell potential is an interesting parameter, for example, fuel cells, batteries, capacitors, dummy cells or electronic components.

### 3.1.2 3-electrode cell connection

The 3-electrode setup is the most common configuration for electrochemical measurements.

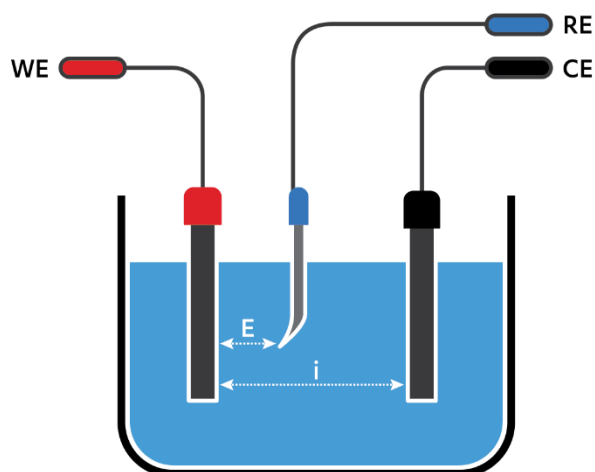

Figure 12 - 3-electrodes cell connection

Similar to the 2-electrode setup, the working electrode carries the current and potential. In this setup, the counter electrode also carries the current and polarizes versus the working electrode (WE). However, the potential is measured between the working and reference electrodes, denoted as WE vs. RE. This potential is the one set and read in the plot results.

The potential WE vs. CE is referred to as the 'cell potential,' and it is recorded in special cases.

In potential-controlled experiments, the potentiostat maintains a loop to ensure that the potential read (WE vs. RE) remains as programmed in the setup, consistently driving this potential towards the WE vs. CE polarization.

This has the advantage that the potential drop across the counter electrodes interface is compensated. Another advantage is that the reference electrode does not carry any current and will thus keep a stable potential during the measurement. This means the potential of the working electrode is more accurate and reproducible.

### 3.1.3 Using the EmStat4T as ZRA

The EmStat4T can also be used as a Zero-Resistance Ammeter (ZRA). A Zero-Resistance Ammeter is a specialized mode used in potentiostats, primarily for measuring current between two electrodes while maintaining zero voltage (potential) difference between them. The ZRA mode ensures that no significant potential is applied between two electrodes, while the current flow between them is accurately measured.

While keeping the potential difference near zero, the potentiostat measures the current flowing between two electrodes. This current is the main variable of interest in ZRA mode, providing valuable insights into processes such as corrosion, galvanic coupling, and other electrochemical phenomena where a potential difference is not deliberately applied but current is exchanged.

If a potentiostat is used as a ZRA, in most setups it needs to be floating (Galvanically Isolated). The reference electrode (blue) and counter electrode (black) connections of the potentiostat need to be stacked and left disconnected to anything else. See the following image for a schematic representation.

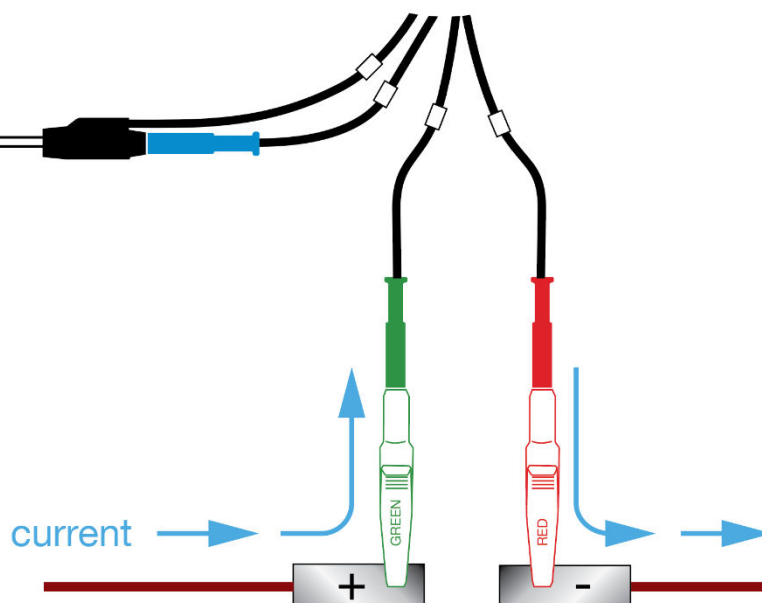

Figure 13 - Connecting the EmStat4T cell cable for ZRA measurements

The current flows through the working electrode lead (red) and the ground lead (green). The working electrode is connected to the input of the current follower and the + input is connected to ground. The voltage difference between the working electrode and ground is zero and the current will be measured.

Use the technique Chronoamperometry in software to record the currents. The applied potential setting can be ignored.

### 3.2 Using Screen-Printed Electrodes (SPEs) with the EmStat4T

This section describes how to use the EmStat4T SPE version with Screen-Printed Electrodes.

The EmStat4T supports direct connection of screen-printed electrodes (SPEs) through the optional SPE Connection Module. This module enables convenient and reliable measurements using disposable or reusable SPEs with standard form factors.

Follow these guidelines while connecting a Screen-Printed Electrode:

1. Gently insert your SPE into the slot of the SPE Connection Module.
2. Ensure the electrode is inserted fully, with all contact pads properly aligned with the module's spring-loaded pins.
3. Avoid excessive force or misalignment to prevent damage to the electrode or the module.

For a list of compatible SPE manufacturers, visit our website:

[www.palmsens.com/products/sensors/screen-printed-electrodes/](http://www.palmsens.com/products/sensors/screen-printed-electrodes/)

### Maintenance and Tips

- Use SPEs only once if they are single-use; do not attempt to clean or reuse unless they are specifically designed for multiple uses.
- Store unused SPEs in a dry, dust-free environment.
- Periodically inspect the SPE Connection Module for debris or wear. Clean gently using a dry, soft brush if necessary.
- When not using SPEs, consider switching back to the SNS Module for conventional cell connections.

For best results, always use screen-printed electrodes that conform to the standard PalmSens-compatible layout. See also section **SPE Connection Module pin-out** on page 26



# 4 Standalone operation

The EmStat4T is capable of running MethodSCRIPTs with the extended command set for controlling the display and internal speaker. This section describes how these scripts – which can be regarded as small apps – can be developed, installed and maintained. The section also covers how the styling and naming of the user interface can be modified.

## 4.1 Developing apps

By using MethodSCRIPT™, small wizard-like apps can be developed for the EmStat4T. These apps can be loaded using the 'Load Script' button which is available in the Idle screen.

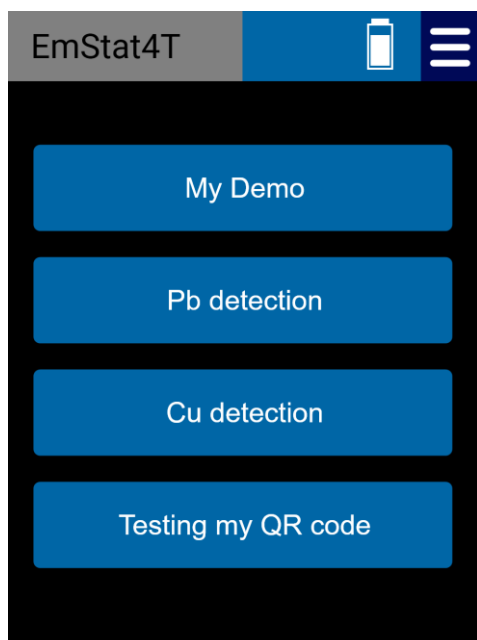

Figure 14 - List with available apps on the display of the EmStat4T

### 4.1.1 Files and folders

The MethodSCRIPTs are stored on the EmStat4T in the folder "display". There are four buttons available on the EmStat4T display to select a script, each button can be considered as a slot. Each script file starts with a number followed by an underscore that defines in which slot the script file is available. The "display" folder can contain for example the following script files:

- 1\_My Demo
- 2\_Pb detection
- 3\_Cu detection
- 4\_Testing my QR code

Each slot contains a file which contains a MethodSCRIPT™ which again can be loaded using the EmStat4T touch screen.

## 4.1.2 Creating and installing an app

The Visual MethodSCRIPT Editor, which can be found in PStace in the main menu: 'Tools' → 'Visual MethodSCRIPT Editor...'

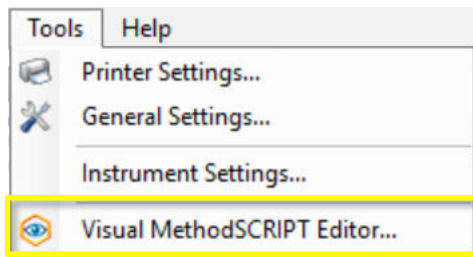

Figure 15 - The Tools menu in PStace 5.12 or later for opening the Visual MethodSCRIPT Editor

## Composing

The Visual MethodSCRIPT Editor allows the user to compose a script by means of dragging and dropping commands from the list at the right-hand side of the window to the script. The software generates the corresponding MethodSCRIPT while composing the script. The script output can be seen in the 'Script Preview' pane. To see the script output click in the menu 'View' → 'Script Preview'.

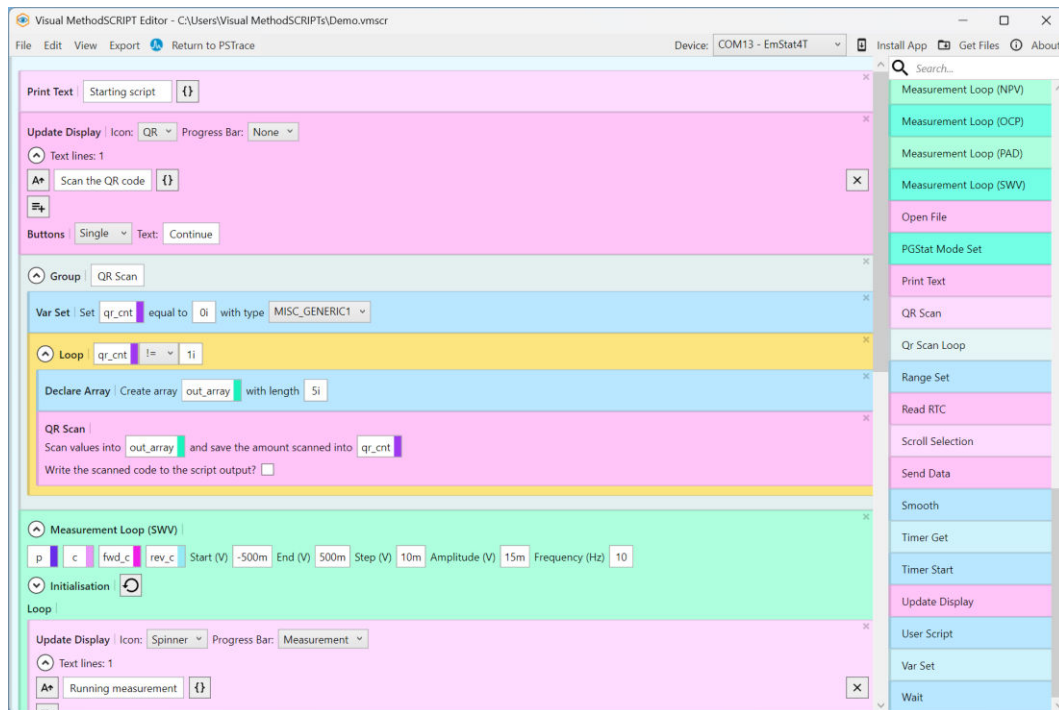

Figure 16 - Visual MethodSCRIPT Editor

## Installing

When a script is ready for installation on the EmStat4T, click on the button 'Install App' which is found at the right-hand side on the Toolbar. This button opens a window 'Download Script to Device'. The window allows you to set a name for the script and choose a slot button to install (see Figure 17) the script in. The new script always overwrites the existing script in the selected slot.

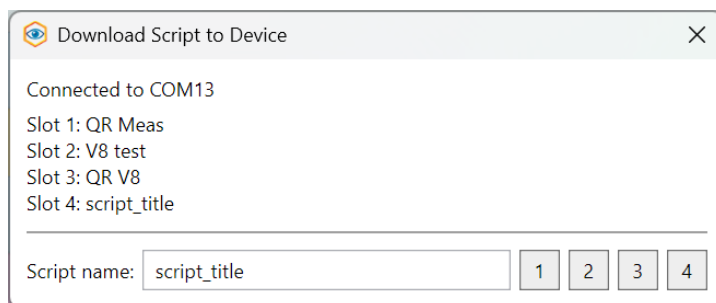

Figure 17 - Downloading a MethodSCRIPT to the EmStat4T

## Deleting

Deleting a script in a slot and making the slot empty again, is possible using the 'Load data from internal storage' window in PSTrace. To open this window click on the main menu in the PSTrace window: 'Data' → 'Load data from internal storage...'

## 4.2 Configuring the style and behavior

Certain images, colors, and labels on the EmStat4T display can be customized to enhance usability for untrained users or to align the user interface with a specific company theme or brand identity.



Figure 18 - EmStat4T display with customized UI

### The EmStat4T Configurator tool window

The EmStat4T Configurator tool window can be found in PSTrace 5.12 or later under the menu 'Tools' → 'Instrument settings...' which opens a window showing the 'EmStat4T Configurator' button. See the figure below.

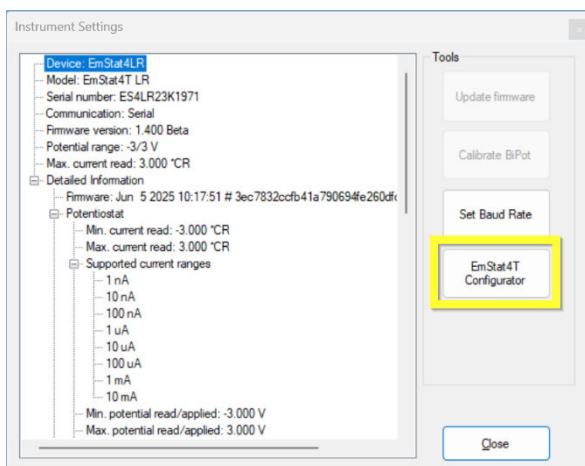

Figure 19 - Instrument Settings window with button to open EmStat4T Configurator

The EmStat4T Configurator window contains the following controls:

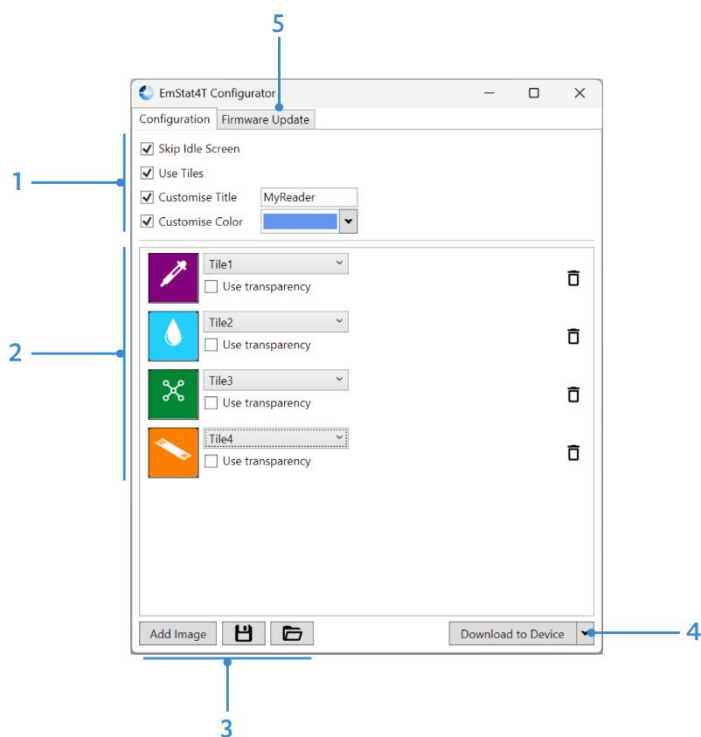

Figure 20 - EmStat4T Configurator tool window

The checkboxes under Figure 20 – 1 change the following settings when enabled:

- **Skip Idle Screen:** when the EmStat4T boots, the screen with cell readings is always skipped and the display shows all the available apps, either as a list or as tiles.
- **Use Tiles:** makes the EmStat4T show tiles instead of a list with the available apps. The tiles can be customized (see Figure 20 – 2) using images.
- **Customise Title:** Replaces the default name “EmStat4T” with a custom one.
- **Customise Color:** Changes the accent colors used in the EmStat4T user interface, for example the button colors.

The area under Figure 20 – 2 contains a list with images that were added using the ‘Add Image’ button. Each button can be configured to be used for a specific purpose. Options include using the image as:

- **Splash:** This image is shown when the EmStat4T boots. The maximum size of the image is 240x320 pixels. It is strongly recommended to use a smaller image to prevent noticeable delays during boot-up.
- **UserIcon#:** These user icons can be used with the ‘Update Display’ command in MethodSCRIPT. The icons should be 80 pixels tall and can be maximum 240 pixels wide.
- **Tile#:** These images are used as icon for the corresponding app when the ‘Use Tiles’ setting is enabled. The size of these images should be 105 x 105 pixels.

The settings can be saved and loaded with the buttons found at the bottom of the screen (Figure 20 – 3). This can be useful if the same settings need to be programmed into new EmStat4T’s.

To store the new settings to the EmStat4T use the ‘Download to Device’ button, see Figure 20 – 4.

### **Firmware updates**

The regular firmware update tool of PStRace cannot be used for firmware updates to the EmStat4T. Use the tab 'Firmware Update' in the EmStat4T Configurator Tool instead (Figure 20 – 5).

See also section **Firmware updates** on page 33

# 5 Specifications

## 5.1 System specifications

The EmStat4T is based on the EmStat4M LR potentiostat module. Specifications are subject to change due to firmware updates; See the EmStat4T product webpage for current, detailed specifications.

Table 2 - EmStat4T-specific specifications

EmStat4T key specifications			
<b>Housing</b>	aluminum body only: 11.1 x 6.0 x 2.7 cm with rubber sleeve: 11.8 x 6.8 x 3.3 cm		
<b>Weight</b>	310 g		
<b>Power source</b>	USB-C or internal Li-Po battery		
<b>Battery</b>	Connected via Bluetooth: ~3 hours with cell on at 10 mA current (~5 hours with cell off)		
<b>Communications</b>	USB Type-C port (recommended USB cable: supplied shielded USB-C to USB-A cable) or Bluetooth (4.0 - Dual-Mode)		
<b>Internal storage</b>	500 MB, equivalent to >15M datapoints		
Integrated QR barcode reader (supported formats and optical depth of field)*			
<b>Compatible Formats</b>	UPC-A, UPC-E, EAN-8, EAN-13, Code 128, GS1-128, Code 39, Code 93, Code 11, Interleaved 2-of-5, Matrix 2-of-5, Industrial 2-of-5, Codabar, MSI, GS1 DataBar, Datalogic 2-of-5, QR Code, Data Matrix, PDF 417, Micro PDF 417, Aztec Code		
<b>Format</b>	<b>Precision</b>	<b>Near</b>	<b>Far</b>
<b>Code 39</b>	0.1 mm (4 mil) – 1.0 mm (40 mil)	25 mm	400 mm
<b>EAN-13</b>	0.33 mm (13 mil)	50 mm	200 mm
<b>QR Code</b>	20.0 mil	30 mm	210 mm

\* Test Conditions: T = 25°C, Illumination = 200 LUX, PCS = 0.9. The data provided above serves as a performance baseline indicative of standard scanner operations. For the complete, comprehensive technical specification visit the EmStat4T product webpage.



Specifications are subject to change, due to firmware updates.  
See the EmStat4T product webpage for current specifications.

## 5.2 SNS Connection Module pin-out

The following schematics show the EmStat4T cell connector pin-out and pin functions.

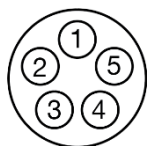

Figure 21 - Front view of the female cell connector on the EmStat4T.

Table 3 - Cell connector pin functions of the EmStat4T.

Pin	Function	Connector color
1	Reference Electrode (RE)	Blue
2	Reference Electrode Shield	N/A
3	Counter / Auxiliary Electrode (CE)	Black
4	NC	N/A
5	Working Electrode (WE)	Red
Connector housing	Analog Ground (AGND)	Green

## 5.3 SPE Connection Module pin-out

The following table shows the EmStat4T SPE connector specifications.

Table 4 - SPE connector specifications of the EmStat4T.

Connection pads	
Connection pads pitch	2.54 mm (0.1")
Allowed sensor thickness	between 0.1 mm and 0.8 mm
Maximum sensor width	10 mm

Ceramic substrates can have very sharp edges that might damage the SPE connector.



When inserting a Screen-Printed Electrode (SPE), avoid touching the electrode areas. Finger contact can contaminate the surfaces and degrade measurement quality. The electrodes also connect directly to sensitive instrument inputs and touching them may cause electrostatic discharge (ESD) that can damage the circuitry.

Handle the sensor only by its non-electrode edges and ensure you are discharged before insertion



# 6 Battery replacement

## Required:

- Screwdriver: Torx 8
- A 3000 mAh LiPo battery acquired from PalmSens BV

## Step 1: Open the battery compartment

Unscrew the single screw and remove the battery lid. Then gently pull on the battery connector to disconnect it.



Figure 22 - EmStat4X with the battery lid removed.

## Step 2: Place the new battery

Connect the new 3000 mAh battery as received from PalmSens BV and place it in the battery compartment with the wires folded at the side of the battery.



The use of an unauthorized battery may compromise safety, pose a risk of fire, and result in irreversible damage to the device.

### **Step 3: Close the housing**

Put the lid and the gasket back in place and close the housing. Do not use excessive force when tightening the screw.

# 7 Troubleshooting

## 7.1 MethodSCRIPT error codes

If the MethodSCRIPT of your EmStat4T app contains an error, a message in red will appear at the bottom of the screen (see figure below).

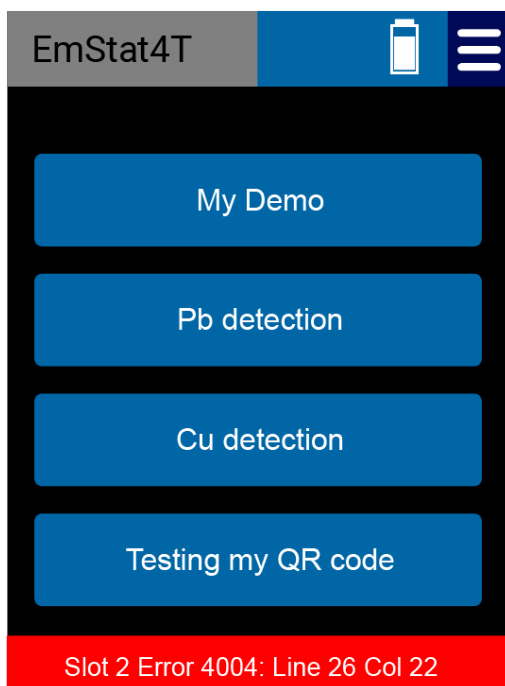

Figure 23 - Example of an error message when trying to run an app

The error code refers to a MethodSCRIPT error code which can be found in appendix A “Error code lookup table” in the MethodSCRIPT documentation. The ‘Line’ number refers to the MethodSCRIPT line number and the ‘Col’ to the position on the line which triggers the error. This could be a missing or faulty argument for example.

See for more information the webpage: [palmsens.com/methodscript](http://palmsens.com/methodscript)

## 7.2 Verifying your potentiostat

Your instrument can be tested by using the test sensor or dummy cell supplied with the instrument.

## Connecting the dummy cell to the EmStat4T SNS

The easiest way to verify the functioning of your instrument is to use the “WE B” circuit, which consists of a resistor with a value of 10 kΩ with a max deviation of 0.1%. The WE+Sense leads are connected to one side and both RE and CE to the other side of the resistor.

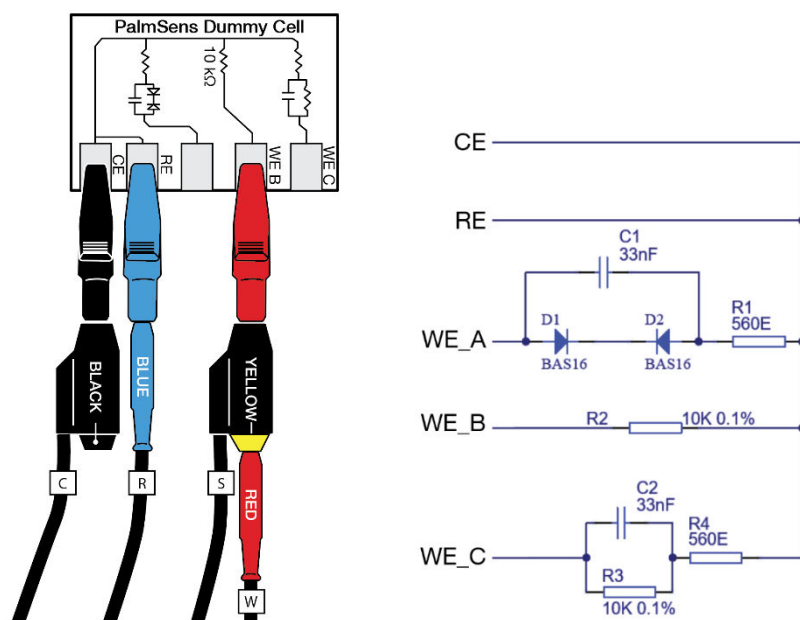

Figure 24 - PalmSens Dummy Cell supplied with the EmStat4T SNS

## Connecting the dummy cell to the EmStat4T SPE

In case you are using the EmStat4R SPE version, connect the SPE dummy cell. Keep in mind that this SPE has a simplified Randles Circuit with an extra 560 Ω resistor in series with the 10 kΩ resistor.



Figure 25 The SPE dummy cell supplied with the EmStat4T SPE

## Running a test measurement on the dummy cell

Any of the electrochemical techniques can be applied. The current response obtained with a resistor with value R is equal to the applied potential or potential pulse divided by the value of R. So, if a potential of 0.5 V is applied on a resistor of 10 kΩ, the obtained current should be  $0.5 \text{ V} / 10 \text{ k}\Omega = 50 \mu\text{A}$ .

Contact PalmSens BV if the problems are found: [info@palmSens.com](mailto:info@palmSens.com) and report the problems as detailed as possible.

## 7.3 Noise troubleshooting

Our instruments are designed with hardware noise suppression filters to reject noise from internal and external sources. If a higher level of noise is your issue, the solving strategies are rather numerous, but the sources for noise are also numerous. Here we describe the most successful and common methods for noise reduction.

To determine the noise levels for your instrument, please refer to section **Measuring the noise level of the instrument** in the PSTrace Manual.

### 7.3.1 Power grid

Your power grid is an alternating current. This undulating current influences the measured currents. PSTrace have a filter for this mains frequency. In PSTrace, check in the 'Tools' menu under 'General Settings' if the mains frequency is set correctly (50 Hz or 60 Hz).

### 7.3.2 Electric fields

Our environment is filled with electric fields. Some of them are created by devices around us as side effects or in case of wireless communication on purpose. Although it is a bad idea to measure directly next to an electric arc furnace, it is usually not possible to have a workspace free of electric fields, especially not during point-of-care measurements.

Nearby RF transmitters (Wi-Fi routers, mobile phones, industrial radios) may be interpreted by the instrument as valid electrochemical signals. Measurements performed near such sources may therefore deviate from stated specifications.

A Faraday cage is usually sufficient to create a field-free environment. A metal box or cage out of metal mesh is a good Faraday cage. Even a shield out of aluminum foil can help. Place your electrochemical cell inside the Faraday cage and connect the cage to the ground lead (green) of the potentiostat. The cable delivered with your instrument has an inbuilt shield and should protect your signal outside the Faraday cage. This is one of the most effective methods to reduce noise.

### 7.3.3 Cables

For optimal electromagnetic compatibility (EMC) and to minimise radiated or conducted interference, PalmSens recommends using only the supplied shielded USB cable. Longer or third-party USB cables may behave as antennas and increase susceptibility to external electromagnetic fields, potentially affecting noise levels and measurement performance.

### 7.3.4 Contacts

Check if the contacts are corroded. If so, remove the stains, for example with sandpaper.

## 7.4 Firmware updates

The regular firmware update tool of PSTrace cannot be used for firmware updates to the EmStat4T. Use the tab 'Firmware Update' in the EmStat4T Configurator Tool instead.

See also section Configuring the style and behavior on page 21

### **Bootloader emergency button**

If the EmStat4T firmware does not start correctly, it is impossible to remotely enter the bootloader to upload new firmware. In this case, a special button in the battery compartment can be used.



Figure 26 - EmStat4T bootloader emergency button

To use this function, open the battery compartment of the EmStat4T and remove the battery. Hold the bootloader button down while connecting the USB cable, and the device will appear as “STM32 Bootloader” for reprogramming.

# 8 Maintenance and compliance

## 8.1 Temperature compliance

Our instruments are designed for indoor use at ambient temperatures between 0 °C and 45 °C. All the components of PalmSens products (except their batteries) are rated to the industrial temperature standard of -40 °C to +85 °C.

## 8.2 Humidity compliance

PalmSens instruments have not been tested in high humidity environments.

Elevated humidity may cause measurement errors if condensation forms on the electronics. This affects measurements mainly in the nA ranges or lower. Prolonged exposure to a condensing environment may severely decrease the life expectancy of the instrument and void its warranty.

## 8.3 Temperature drift

PalmSens instruments are calibrated at 21 °C. The most sensitive components of the instrument have temperature drift of 50 ppm. For instance, at 1 °C or 41 °C, measurement drift of up to 0.1% may be experienced.

## 8.4 Atmospheric pressure

PalmSens instruments are not intended for use in safety-critical applications. Consequently, the power supplies utilized are not selected based on a specific pressure rating.

## 8.5 Cleaning

Make sure to disconnect your instrument from any cell or power source, if applicable, prior to cleaning. Use a lightly dampened cloth with either clean water or water containing a mild detergent to clean the outside of the instrument. Alternatively, you can use isopropyl alcohol. Avoid using a wet rag and prevent any fluids from entering the instrument. It is crucial not to immerse the instrument in any cleaning solution.

## 8.6 Periodic calibration and preventive maintenance

PalmSens instruments are designed in a way that eliminates the need for periodic calibration. While not mandatory, PalmSens does provide a calibration service for users with specific demands such as QC/ISO purposes. This service includes a new calibration certificate.

PalmSens instruments do not require preventive maintenance, further simplifying their use and reducing the overall maintenance demands on users.

## **8.7 Service and repair**

Your PalmSens instrument contains no user-serviceable parts internally. Any service or maintenance needs should be directed to a qualified service technician employed or authorized by PalmSens BV. Attempting to access or modify internal components without proper expertise may result in additional damage to the instrument and voids warranty. It is recommended to rely on authorized service personnel for any required maintenance or repairs.

## **8.8 RoHS Compliance**

All instruments from PalmSens have been built using lead-free components and lead-free solder. They are in compliance with the European RoHS initiative.

## 9 Licenses

This section provides an overview of the open-source software components used in this product, which are licensed under the MIT License. Each component is distributed under its own license terms, which permits the free use, modification, and distribution of the software. Below, you will find the relevant copyright notices and license texts for these components, ensuring compliance with the terms of the MIT License.

By including these licenses, we acknowledge and respect the contributions of the respective authors and maintain transparency about the usage of third-party open-source software.

FreeRTOS (MIT):

<https://www.freertos.org/Documentation/02-Kernel/01-About-the-FreeRTOS-kernel/04-Licensing>

eyalroz/printf (MIT):

<https://github.com/eyalroz/printf/blob/master/LICENSE>

mcufont (MIT):

<https://github.com/mcufont/mcufont/blob/master/LICENSE>

## A. EU Waste Electrical and Electronic Equipment (WEEE) Directive

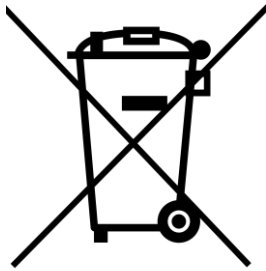

The pictogram shown above, located on the product(s) and / or accompanying documents means that used electrical and electronic equipment (WEEE) should not be mixed with general household waste. For proper treatment, recovery and recycling, please take this product(s) to designated collection points where it will be accepted free of charge.

Alternatively, in some countries, you may be able to return your products to your local retailer upon purchase of an equivalent new product. Disposing of this product correctly will help save valuable resources and prevent any potential negative effects on human health and the environment, which could otherwise arise from inappropriate waste handling. Please contact your local authority for further details of your nearest designated collection point. Penalties may be applicable for incorrect disposal of this waste, in accordance with your national legislation.

## B. EU Declaration of Conformity



### EU DECLARATION OF CONFORMITY



Certificate number: PSDOC-ES4T-A

**Manufacturer:** PalmSens BV  
**Address:** Vleugelboot 22,  
3991 CL Houten,  
The Netherlands

This declaration is valid for the following product:

**EmStat4T:** Portable electrochemical analyser with touch interface.

- USB power and communications
- Battery power
- Bluetooth communication

The object of the declaration described above is in conformity with the Radio Emissions Directive 2014/53/EU (RED) and applicable standards listed below:

Health & Safety

- EN 62479
- EN 61010-1

EMC

- EN 61326-1
- EN 301 489 parts 1 & 17

Efficient Usage of Radio Spectrum

- EN 300 328

This declaration is issued under the sole responsibility of PalmSens BV.

Date: 1<sup>st</sup> of August 2025

A handwritten signature in black ink, appearing to read "C.J. van Velzen", with a long horizontal stroke extending to the right.

C.J. van Velzen, CTO





**Published by**

PalmSens BV  
Vleugelboot 22  
3991 CL Houten  
The Netherlands

© 2026 PalmSens BV  
All rights reserved.

