



Sensit BT

Operator's Manual

PalmSens BV
Version 016, 2026-07-01

If you have problems

First make sure to check the “Troubleshooting” section in this document and the Knowledge Base on our website: www.palmsens.com/knowledgebase/. This page contains support information on installation, software updates, and training. Please make sure your software and firmware are up-to-date.



In case of persistent problems

- Use the contact form: www.palmsens.com/contact/
- Give us a call: +31 30 2459211
- Or send an email: info@palmsens.com

Please describe the problem in as much detail as possible. Sending us the relevant method files, data files and screenshots can be helpful. Please include your instrument model and serial numbers, as well as any applicable software and firmware version you are using.

Limited Warranty

Except as otherwise provided herein, PalmSens BV warrants to buyer three years from the date title to the product passes (transfer date of goods from seller to buyer), each product sold hereunder will be free of defects in materials or workmanship and will conform to specifications set forth in PalmSens BV’s published data sheets or, where applicable, operator’s manuals for PalmSens BV’s system products in effect at the time title passes.

PalmSens BV’s sole liability and responsibility for products under this warranty is for PalmSens BV to repair or replace any product that is returned to it by buyer or credit buyer’s account for such returned product, provided that PalmSens BV shall have the right to reject any such remedy where PalmSens BV determines that the warranty does not apply. Products returned to PalmSens BV for warranty service will be shipped to PalmSens BV at buyer’s expense and will be returned to buyer at PalmSens BV’s expense. PalmSens BV’s obligation to honor its warranty for a product is contingent upon receipt of payment in full for such product.

See our website for more detailed information:
www.palmsens.com/terms-and-conditions/

Disclaimers

PalmSens BV is not liable for any direct, indirect, incidental, or consequential damages resulting from the use or misuse of its instruments, including but not limited to:

- Damage to the instrument caused by improper handling, unauthorized modifications, or use outside the recommended specifications.
- Malfunction or incorrect results due to improper sample preparation, contamination, or incorrect experimental setup.
- Loss of data or research results caused by software crashes, hardware failures, or power interruptions.
- Personal injury or property damage resulting from incorrect wiring, exposure to hazardous chemicals, or misuse of electrical connections.

Results obtained using PalmSens instruments depend on experimental conditions, sample properties, and user expertise. Users are responsible for verifying the validity of their data. Changes in specifications and typing errors reserved. Every effort has been made to ensure the accuracy of this document. However, no rights can be claimed by the contents of this document.

By using PalmSens instruments, the user acknowledges and accepts these limitations and responsibilities.

See Appendix A for CE declaration of conformity.

Copyrights

Sensit BT – Operator’s Manual.

Copyright © 2024-2026, PalmSens BV, all rights reserved.

PSTrace, MultiTrace, Nexus, PalmSens, EmStat, MultiEmStat, Sensit and Lablink are trademarks of PalmSens BV.

No part of this document may be copied or reproduced in any form without the prior written consent of PalmSens BV.



Table of Contents

1. Introduction	1
1.1. Scope of this manual	1
1.2. About the Sensit BT	1
2. Operating the Sensit BT	3
2.1. USB and charging	3
2.2. Bluetooth	3
2.3. Cell connections	3
2.4. Cell cable pin-out (.SNS)	5
2.5. BiPotentiostat (.SNS)	5
2.6. SPE connector pin-out (.SPE)	6
2.7. Replacing the SPE connectors (.SPE)	6
2.8. Status LED indicators	6
2.9. Sensit BT trigger button	7
3. Battery replacement	11
3.1. Procedure	11
4. Specifications	13
5. Troubleshooting	15
5.1. Verifying your potentiostat	15
5.2. Noise	16
5.3. Power grid	16
5.4. Electric fields	16
5.5. Cables	16
5.6. Contacts	16
6. Maintenance and compliance	17
6.1. Lithium-Polymer batteries	17
6.2. Temperature compliance	17
6.3. Humidity compliance	17
6.4. Temperature drift	17
6.5. Atmospheric pressure	17
6.6. Cleaning	18

6.7. Periodic calibration and preventive maintenance	18
6.8. Service and repair	18
6.9. RoHS Compliance	18
Appendix A: CE Declaration	19
Appendix B: EU Waste Electrical and Electronic Equipment (WEEE) Directive	21

Chapter 1. Introduction

1.1. Scope of this manual

This manual covers the handling, characteristics, troubleshooting, and other practical information regarding the hardware specifics of the Sensit BT, as well as maintenance and compliance.

Please refer to the **Quick Installation Guide** that was supplied with the instrument for instructions on installing the instrument and the software. Additionally, the section **Getting Started** in the digital **PSTrace Manual**, that is installed with the software, provides detailed instructions for conducting first measurements with your instrument.



Initial setup and basic operational instructions for conducting initial measurements are detailed in the "Quick Installation Guide" supplied with the instrument.

The PSTrace Manual is an in-depth document covering not only the PSTrace software but also the hardware limitations for each technique supported by the instrument. It is written to give you a full understanding of both the software and hardware aspects, making sure you are well equipped to use all the functionalities of the Sensit BT.

1.2. About the Sensit BT

The Sensit BT is a small and lightweight potentiostat which incorporates a battery, Bluetooth connection, internal memory, power switch, trigger button, and LED indicators. The Sensit BT connects to smartphones or tablets via Bluetooth, controlled through the Android app PStouch. Charging or PC connection is facilitated through the USB-C port, enabling control via PC software PSTrace.

The cell interface of the Sensit BT can either be in the form of a short cable with 2 mm pins and/or crocodile clips or in the form of two connectors for Screen-Printed Electrodes, or SPEs. See Figure 1 below.



Figure 1. The Sensit BT is available in two different versions.

The Sensit BT has been on the market since 2019 and is also available as a tailored instrument for OEM purposes. The Sensit BT works with the EmStat Pico potentiostat module, which is also available separately for integration in third-party systems. See the OEM section on our website for more information.

Chapter 2. Operating the Sensit BT

2.1. USB and charging

The Sensit BT has a USB Type-C (USB-C) port and uses the High-Speed USB 2.0 specification. The instrument comes standard with a shielded USB-C to USB-A (standard rectangular plug) cable and can be used with any standard USB port.

When the Sensit BT is connected to a USB port which is either a USB power source or host it will charge the battery. A full charge of the Sensit BT takes less than three hours, after which it can be used for at least 12 hours.

The white LED will blink slowly while the instrument is charging, and the power button is set to on. When the instrument is powered off, the LED will not blink, but the battery will still be charged.

2.2. Bluetooth

Every Sensit BT has a unique Bluetooth identifier. The Bluetooth identifier always starts with the letters PS, followed by a dash and the last four characters of its MAC address. For example: PS-F93A. The Bluetooth MAC address of the Sensit BT can be found on the bottom of the instrument, see Figure 2.

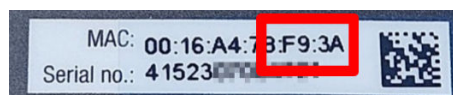

Figure 2. The last four characters of the MAC address.

When connecting to the USB port of a PC, Bluetooth will switch off automatically unless there is a Bluetooth connection active. This allows the instrument to be charged via the PC while a Bluetooth connection is present. See also section: “Connecting using Bluetooth” in the PSTrace Manual.

2.3. Cell connections

The Sensit BT comes in two different versions: SPE and SNS.

The Sensit BT.SPE can be used for running sequential measurements on two different Screen-Printed Electrodes (SPEs) each with their own Reference, Counter and Working electrodes. The second channel can also be used in Bipotentiostat mode, functioning as second Working Electrode versus the Reference and Counter electrode of channel 1. Both Working electrodes are recorded simultaneously in the

Bipotentiostat mode. A connector for a SPE with 2 WEs is available on request.

The Sensit BT.**SNS** has a lead connected to the WE of channel 2 and can be used out-of-the-box for BiPotentiostat measurements. The second Working Electrode (WE2) can either be set at a potential offset with respect to WE1 or at a fixed potential with respect to RE1. The Bipotentiostat mode is supported in Low Speed mode for all techniques, excluding EIS and OCP.

Table 1. Sensit BT specifications

Sensit BT.SPE		Sensit BT.SNS	
			
Sensor pitch	2.54 mm	Cable length	40 cm
Electrode connections	2x CE, WE, RE	Connectors	2 mm
Allowed sensor thickness	between 0.1 and 0.8 mm	Electrode connections	RE, WE, WE2, CE
Maximum sensor width	11 mm		

For more information about making a connection to the cell, see also section: **“Connecting a cell to the potentiostat”** in the PSTrace Manual.

2.4. Cell cable pin-out (.SNS)

The following table shows the function for each lead on the cell cable of the Sensit BT.SNS.

Table 2. Cell connector cable leads functions of the Sensit BT.SNS

Label	Connector color	Function
RE	Blue	Reference Electrode (RE)
CE	Black	Counter / Auxiliary Electrode (CE)
W1	Red	Working Electrode 1 (WE1)
W2	Yellow	Working Electrode 2 (BiPotentiostat)
\perp	Green	Analog Ground (AGND)

In order to make use of the WE2 functionality, please make sure to enable **"BiPot present"** in the settings of PSTrace.

2.5. BiPotentiostat (.SNS)



Only the Sensit BT.SNS (with cable) has the additional W2 lead for using the instrument as BiPotentiostat.

"BiPot" stands for BiPotentiostat, which is a potentiostat with two working electrodes. A bipotentiostat can use two working electrodes, one reference and one counter in the same cell. The two working electrodes can be operated and monitored exactly at the same time.

Working electrode 1 performs any of the supported techniques (see below), while working electrode 2 can either have its own constant potential or follow the working potential of electrode 1. In the latter case a potential offset can be added.

2.5.1. Application examples

- Second electrode as a blank or similar in the same cell for comparison
- Detecting the product of the disc electrode's reaction at the ring of a RRDE (Rotating Ring Disc Electrode)
- Polarize the surface during scanning electrochemical microscopy (SECM)
- Controlling gate voltage and source-drain voltage of an ion selective field effect transistors (ISFET)

2.5.2. Supported techniques for use with bipotentiostat

The following techniques are supported for using the W2 lead with the Sensit BT.SNS in bipotentiostat mode:

- Linear Sweep Voltammetry
- Cyclic Voltammetry
- Amperometric Detection
- Multistep Amperometry

Please refer to section “Using a BiPot” in the PSTrace Manual, for more information.

2.6. SPE connector pin-out (.SPE)

The Sensit BT.SPE version has two connectors for Screen-Printed Electrodes. These electrodes should match the following specifications, shown in the table below.

Table 3. SPE connector specifications of the Sensit BT.SPE.

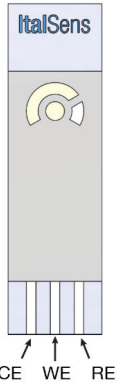
Connection pads	
Connection pads pitch	2.54 mm (0.1")
Sensor thickness	0.1 to 0.8 mm
Max. sensor width	10 mm

2.7. Replacing the SPE connectors (.SPE)

An online video is available that explains how to replace the SPE connectors of your Sensit BT.SPE. Please follow this link to see the tutorial: www.palmsens.com/bt-tt1/.

2.8. Status LED indicators

The LEDs indicate in which state the device is in.

The cell indicator ('CELL') turns red whenever the cell is on, which means the Counter Electrode is connected internally and current can flow. If the cell indicator is

off, the cell is at open circuit (OCP) and only potentials can be measured. The Bluetooth indicator ('BLUETOOTH') is solid blue when a Bluetooth connection is established. The indicator will turn off again when the Bluetooth connection is severed. The power indicator ('POWER') is solid white when the instrument is powered on. During charging the power indicator will slowly blink in case the instrument is powered on as well. If the instrument is powered off during charging, it will still charge the battery, however the power indicator will remain off. If the battery charge is low, the power icon will flash briefly every three seconds.

2.9. Sensit BT trigger button

The Sensit BT trigger button is not supported natively in PSTrace but can be used with custom MethodSCRIPTs. The button can be configured in such a way that each push starts a measurement and stores the measured data on the on-board storage.



Figure 3. Trigger button on Sensit BT.

Please refer to the section “**MethodSCRIPT Sandbox**” in the PSTrace Manual on how to create a customised MethodSCRIPT for the Sensit BT. The example below shows how the line 'hibernate 0x07i 60' can be used to wake up and continue when the trigger button is used.

```

e
var c
var p
var f
var g
var i
store_var i 0i aa
loop i < 2i
  hibernate 0x07i 60
  ##### Measurement initialisation #####
  set_pgstat_chan 0
  set_pgstat_mode 2
  set_max_bandwidth 200
  set_range_minmax da -400m 400m
  set_range ba 59n
  set_autoranging ba 59n 59n
  set_e -300m
  cell_on
  ##### Run measurement #####
  # Perform SWV measurement from -300 mV to 300 mV at 5 Hz
  meas_loop_swv p c f g -300m 300m 10m 100m 10
  ##### Send measurement package #####
  pck_start
    # Sweep potential
    pck_add p
    # Current
    pck_add c
  pck_end
endloop
add_var i 1i
cell_off
endloop
on_finished:

```

This MethodSCRIPT™ trigger button example, and more examples can be found on: www.github.com/palmsens.

Compliance voltage limitation

The Sensit series are based on the EmStat Pico modules which have a limited compliance voltage. The compliance voltage is the maximum voltage that can be applied between the working and counter electrode. Another name could be the maximum cell potential.



The Sensit series is based on the EmStat Pico modules which have a limited compliance voltage.

The higher the current at the working electrode, the higher the current required at the counter electrode. To increase the current the potentiostat increases the potential difference between the working and counter electrode. At some point, the maximum cell potential is reached and cannot be increased further.

This means the working electrode's potential might not be correct anymore, because the correct current cannot flow through the counter electrode anymore. The potentiostat ran into its compliance voltage. The potential of the working electrode will stay at the last value it could reach.

During DPV or SWV this means the differential is 0 and thus the curve shows a sudden drop in current and stays at 0. In a Cyclic Voltammogram reaching the compliance voltage is clearly visible. The constant potential will lead to a current following the Cottrell equation:

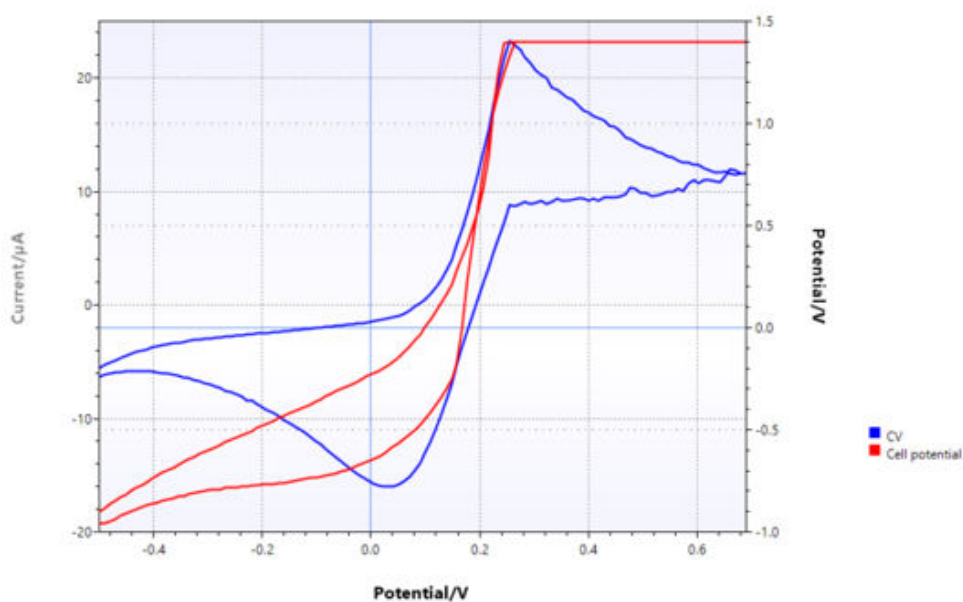

Figure 4. Typical CV showing an exceeded maximum compliance voltage.

Chapter 3. Battery replacement



Important Information:

The internal Li-Po battery in the Sensit BT instrument is not user-replaceable. To ensure safety, proper functionality, and compliance with warranty terms, only individuals trained and authorized by PalmSens BV should perform the replacement.

3.1. Procedure

Contact PalmSens BV: If you suspect that your Sensit BT instrument's internal Li-Po battery requires replacement, please reach out to PalmSens BV through our official channels.

Authorized Personnel Only: Our trained technicians are equipped with the necessary expertise and tools to safely replace the internal Li-Po battery. Attempting to replace the battery yourself may result in damage to the instrument or compromise safety.

Arrange Service: Coordinate with PalmSens BV to arrange a battery replacement service. Our team will guide you through the necessary steps and logistics.

Warranty Considerations: Please be aware that unauthorized battery replacement may void your warranty. Ensure that all service and maintenance are performed by PalmSens BV or our authorized representatives to maintain warranty coverage.



For inquiries related to battery replacement or any other service, please contact PalmSens BV.

Chapter 4. Specifications

The Sensit BT incorporates the EmStat Pico potentiostat module, which works in different operational modes. The optimal mode is automatically selected when using our PSTrace or PStouch software. The following table shows the specifications of the Sensit BT for each operational mode.

Table 4. Sensit BT specifications

	Low Speed Mode	High Speed Mode	Max Range Mode
dc-potential range	-1.2 to +2 V	-1.7 to +2 V	-1.7 to +2 V
Dynamic dc-potential range *	2.2 V	1.2 V	2.6 V
Compliance voltage	-2.0 to 2.3 V		
Maximum current	± 3 mA		
Max. acquisition rate (datapoints/s)	100	1000	100
Supports FRA/EIS	NO	YES	NO

**The dynamic range is the range that can be covered during a single scan within the full potential range. For example, a linear scan can start at -1.5 V and end at 1.1 V or vice versa, covering 2.6 V dynamic range.*

Specifications are subject to change, due to regular firmware updates. See the Sensit BT product page on our website for detailed technical specifications:
www.palmsens.com/bt.

Chapter 5. Troubleshooting

5.1. Verifying your potentiostat

Your instrument can be tested by using the test sensor or dummy cell supplied with the instrument.

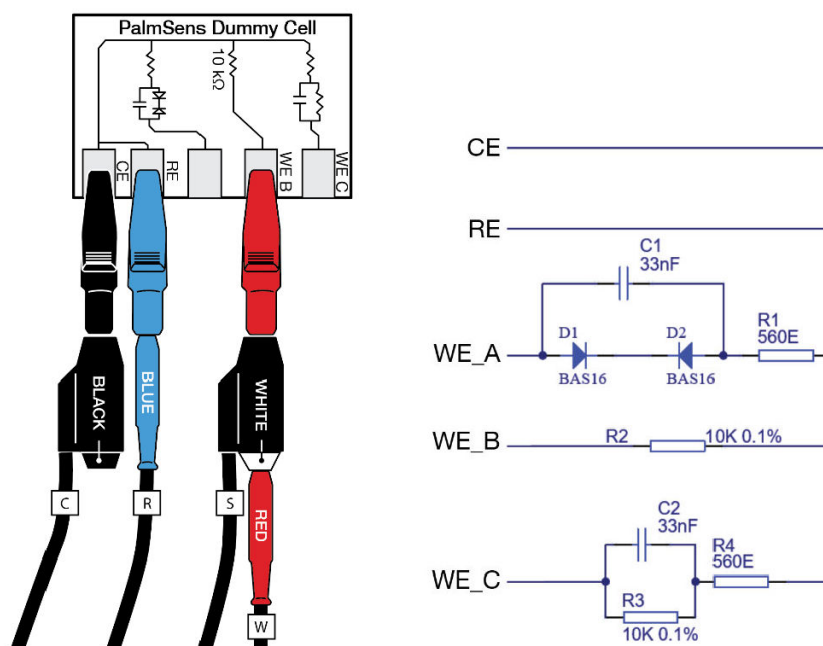

Figure 5. PalmSens Dummy Cell

The easiest way to verify the functioning of your instrument is to use the “WE B” circuit, which consists of a resistor with a value of 10 kΩ with a max deviation of 0.1%.

The WE lead is connected to one side and both RE and CE to the other side of the resistor.

Any of the electrochemical techniques can be applied. The current response obtained with a resistor with value R is equal to the applied potential or potential pulse divided by the value of R. So, if a potential of 0.5 V is applied on a resistor of 10 kΩ, the obtained current should be $0.5 \text{ V} / 10 \text{ k}\Omega = 50 \mu\text{A}$.

Contact PalmSens BV if problems are found: info@palsens.com and report the problems in as much detail as possible.

5.2. Noise

Our instruments are designed with hardware noise suppression filters to reject noise from internal and external sources. If a higher level of noise is your issue, the solving strategies are rather numerous, but the sources for noise are also numerous. Here we describe the most successful and common methods for noise reduction.

To determine the noise levels for your instrument, please refer to section **"Measuring the noise level of the instrument"** in the PSTrace Manual.

5.3. Power grid

Your power grid is usually using an alternating current. This undulating current influences the measured currents. PSTrace and PSTouch have a filter for this mains frequency. In PSTrace, check in the 'Tools' menu under 'General Settings' if the mains frequency is set correctly (50 Hz or 60 Hz).

5.4. Electric fields

Our environment is filled with electric fields. Some of them are created by devices around us as side effects or in case of wireless communication on purpose. Although it is a bad idea to measure directly next to an electric arc furnace, it is usually not possible to have a workspace free of electric fields, especially not during point-of-care measurements. A Faraday cage is usually sufficient to create a field-free environment. A metal box or cage out of metal mesh is a good Faraday cage. Even a shield out of aluminum foil can help. Place your electrochemical cell inside the Faraday cage and connect the cage to the ground lead (green) of the potentiostat. The cable delivered with your instrument has an inbuilt shield and should protect your signal outside the Faraday cage. This is one of the most effective methods to reduce noise.

5.5. Cables

Cables should not be unnecessarily long, since they act as antennas for noise, but the cable delivered with your instrument has an inbuilt shield and as long as you use the original cable, there is little reason to worry about cable induced noise.

5.6. Contacts

Check if the contacts are corroded. If so, remove the stains, for example with sandpaper.

Chapter 6. Maintenance and compliance

6.1. Lithium-Polymer batteries

The typical estimated life of a Lithium-Polymer battery is about two to three years or 300 to 500 charge cycles, whichever occurs first. One charge cycle is a period of use from fully charged, to fully discharged, and fully recharged again. Consider a two-to-three-year life expectancy for batteries that do not run through complete charge cycles.

Rechargeable Lithium-Polymer batteries have a limited life and will gradually lose their capacity to hold a charge. This loss of capacity (aging) is irreversible. As the battery loses capacity, the length of time it will power the product (run time) decreases. Lithium-Ion batteries continue to slowly discharge (self-discharge) when not in use or while in storage.

6.2. Temperature compliance

Our instruments are designed for indoor use at ambient temperatures between 0 °C and 45 °C. The battery of the Sensit BT is rated from -20 °C to +60 °C when discharging and from 0 °C to +45 °C when charging.

6.3. Humidity compliance

PalmSens instruments have not been tested in high humidity environments.

Elevated humidity may cause measurement errors if condensation forms on the electronics. This affects measurements mainly in the nA ranges or lower. Prolonged exposure to a condensing environment may severely decrease the life expectancy of the instrument and void its warranty.

6.4. Temperature drift

PalmSens instruments are calibrated at 21 °C. The most sensitive components of the instrument have temperature drift of 50 ppm. For instance, at 1 °C or 41 °C, measurement drift of up to 0.1% may be experienced.

6.5. Atmospheric pressure

PalmSens instruments are not intended for use in safety-critical applications. Consequently, the power supplies utilized are not selected based on a specific pressure rating.

6.6. Cleaning

Make sure to disconnect your instrument from any cell or power source, if applicable, prior to cleaning. Use a lightly dampened cloth with either clean water or water containing a mild detergent to clean the outside of the instrument.

Alternatively, you can use isopropyl alcohol. Avoid using a wet rag and prevent any fluids from entering the instrument. It is crucial not to immerse the instrument in any cleaning solution.

6.7. Periodic calibration and preventive maintenance

PalmSens instruments are designed in a way that eliminates the need for periodic calibration. While not mandatory, PalmSens does provide a calibration service for users with specific demands such as QC/ISO purposes. This service includes a new calibration certificate.

PalmSens instruments do not require preventive maintenance, further simplifying their use and reducing the overall maintenance demands on users.

6.8. Service and repair

Your PalmSens instrument contains no user-serviceable parts internally. Any service or maintenance needs should be directed to a qualified service technician employed or authorized by PalmSens BV. Attempting to access or modify internal components without proper expertise may result in additional damage to the instrument and voids warranty. It is recommended to rely on authorized service personnel for any required maintenance or repairs.

6.9. RoHS Compliance

All instruments from PalmSens have been built using lead-free components and lead-free solder. They are in compliance with the European RoHS (Restriction of Hazardous Substances) initiative.

Appendix A: CE Declaration



EU DECLARATION OF CONFORMITY

Certificate number: PSDOC-SBT-B



Manufacturer: PalmSens BV
Address: Vleugelboot 22,
3991 CL Houten,
The Netherlands

This declaration is valid for the following product:

Sensit BT, Portable electrochemical analyser

- USB power and communications
- Battery power
- Bluetooth communication
- 0.4 meter cell cable

The object of the declaration described above is in conformity with the Radio Emissions Directive 2014/53/EU (RED) and applicable standards listed below:

Health & Safety

- EN 62479
- EN 61010-1

EMC

- EN 61326-1
- EN 301 489 parts 1 & 17

Efficient Usage of Radio Spectrum

- EN 300 328

This declaration is issued under the sole responsibility of PalmSens BV.

Date: 29th of November 2023

A handwritten signature in black ink, appearing to read "C.J. van Velzen".

C.J. van Velzen, CTO

Appendix B: EU Waste Electrical and Electronic Equipment (WEEE) Directive



The pictogram shown above, located on the product and/or accompanying documents means that used electrical and electronic equipment (WEEE) should not be mixed with general household waste. For proper treatment, recovery and recycling, please take this product to designated collection points where it will be accepted free of charge.

Alternatively, in some countries, you may be able to return your product to your local retailer upon purchase of an equivalent new product. Disposing of this product correctly will help save valuable resources and prevent any potential negative effects on human health and the environment, which could otherwise arise from inappropriate waste handling. Please contact your local authority for further details of your nearest designated collection point. Penalties may be applicable for incorrect disposal of this waste, in accordance with your national legislation.

Published by

PalmSens BV
Vleugelboot 22
3991 CL Houten
The Netherlands

© 2026 PalmSens BV
All rights reserved

